



Operating / Installation Manual

FV-ST51

Please read this manual carefully  
before using the appliance.

Safety Information .....	3
Description of your oven.....	6
Basic settings .....	8
Basic functions .....	11
Special Functions .....	12
Water feeding .....	14
When the oven is working.....	15
Usage, Tables and Tips .....	17
Care and maintenance .....	22
Oven Cleaning.....	25
What should I do if the oven doesn't work? .....	26
Technical characteristics .....	27
Environmental protection .....	28
Installation instructions .....	29
Installation.....	30

Dear Customer,

Thank you for choosing this **FUJIOH** product.

We ask you to read the instructions in this booklet very carefully as this will allow you to get the best results from using it.

**KEEP THE DOCUMENTATION OF THIS PRODUCT FOR FUTURE REFERENCE.**

**Always keep the instruction manual handy. If you lend the appliance to someone else give them the manual as well!**

## Safety Information



Before the installation and use of the appliance, carefully read the supplied instructions. The manufacturer is not responsible if an incorrect installation and use causes injuries and damages. Always keep the instructions with the appliance for future reference.

### CHILDREN AND VULNERABLE PEOPLE SAFETY

- **Warning!** Risk of suffocation, injury or permanent disability.
- This appliance can be used by children aged from 8 years and above and persons with reduced physical, sensory or mental capabilities or lack of experience and knowledge if they are supervised by an adult or a person who is responsible for their safety.
- Do not let children play with the appliance.
- Keep all packaging away from children.
- **WARNING:** Keep children away from the appliance when it operates or when it cools down. Accessible parts are hot.
- If the appliance has a child safety device, we recommend that you activate it. Children under 3 years must not be left unsupervised in the vicinity of the appliance.
- Cleaning and user maintenance shall not be made by children without supervision.

### GENERAL SAFETY

- This appliance is intended to be used in household and similar applications such as:
  - staff kitchen areas in shops, offices and other working environments;
  - farm houses;
  - by clients in hotels, motels and other residential environments;
  - bed and breakfast type environments.
- Internally the appliance becomes hot when in operation. Do not touch the heating elements that are in the appliance. Always use oven gloves to remove or put in accessories or ovenware.

- The appliance is intended for heating food and beverages. Drying of food or clothing and heating of warming pads, slippers, sponges, damp cloth and similar may lead to risk of injury, ignition or fire.
- Make sure you never catch the power cables of other electrical appliances in the hot door or the oven. The cable insulation may melt. **Danger of short-circuiting!**
- Do not lean or sit on the open oven door. This may damage the oven, especially in the hinge zone. The door can bear a maximum weight of 8 kg.
- The grills can bear a maximum load of 8 kg. To avoid damaging the oven, do not exceed this load.

## **INSTALLATION**

- The electric system must be equipped with a means for disconnection, with a contact separation in all poles that provides full disconnection under overvoltage category III.
- If a plug is used for the electric connection, then it must be accessible after installation.
- If the electrical connection is done through a plug and this remains accessible after installation, then it is not necessary to provide the mentioned separation device.
- Protection against electric shock must be provided by the electrical installation
- **Warning:** The oven must be earthed.

## **CLEANING**

- The appliance should be cleaned regularly and any food deposits removed.
- Failure to maintain the appliance in a clean condition could lead to deterioration of the surface that could adversely affect the life of the appliance and possibly result in a hazardous situation.

## Safety Information

- Do not use harsh abrasive cleaners or sharp metal scrapers to clean the glass door since they can scratch the surface, which may result in shattering of the glass.
- Do not use a steam cleaner to clean the appliance.
- Please follow the instructions regarding cleaning in the section "Oven Cleaning and Maintenance".

## REPAIRS

- **WARNING:** Before maintenance cut the power supply.
- If the power cable is damaged it should be substituted by the manufacturer, authorized agents or technicians qualified for this task in order to avoid dangerous situations. Furthermore, special tools are required for this task.
- Repair and maintenance work, especially of current carrying parts, can only be carried out by technicians authorized by the manufacturer.

# Description of your oven

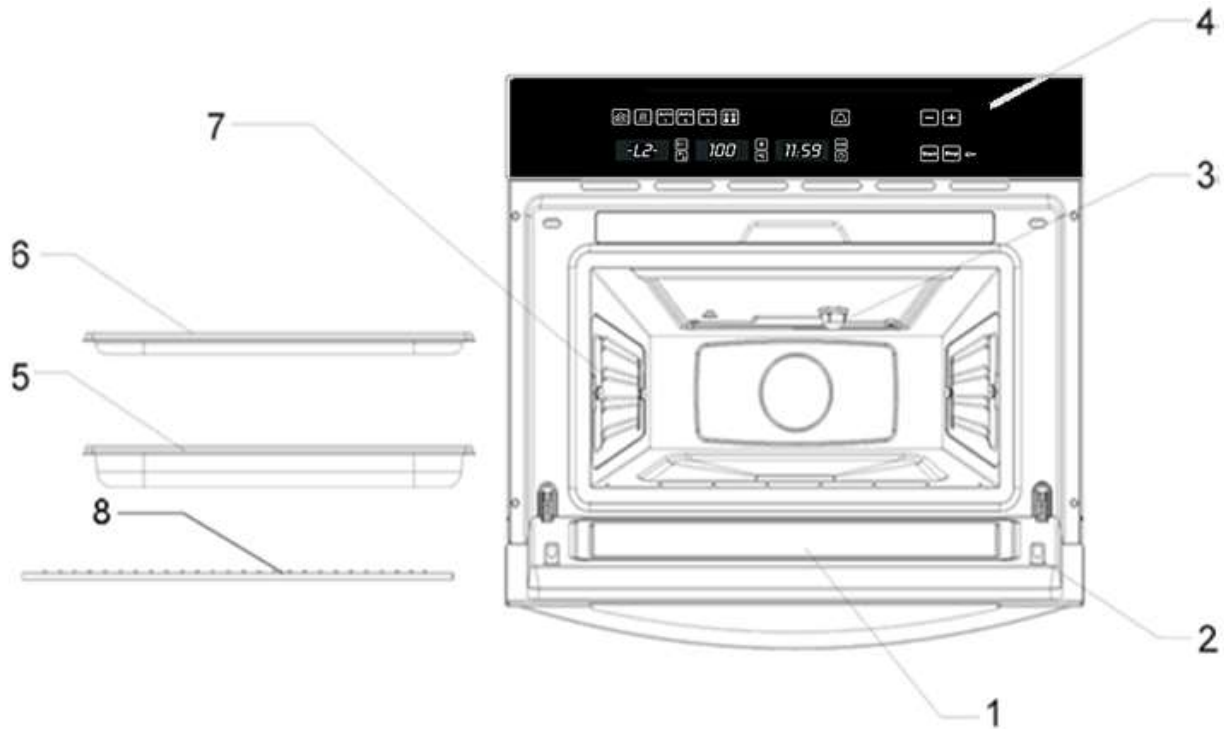

- 1. – Door window glass
- 2. – Safety catches
- 3. – Lamp bulb
- 4. – Control panel



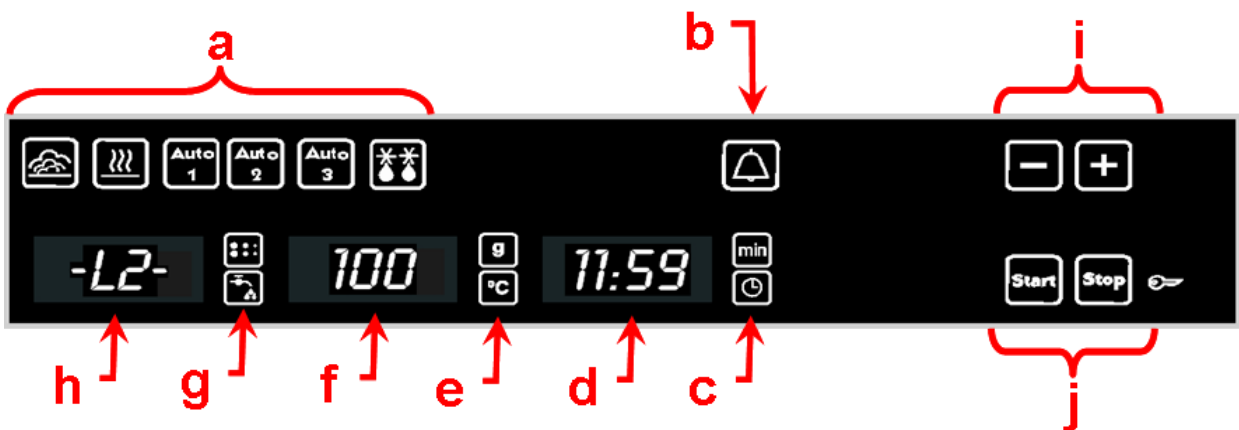



- 5. – Baking tray
- 6. – Perforated baking tray
- 7. – Shelf guides
- 8. – Rack



- a. – Function lights
- b. – Timer light
- c. – Clock / Duration / Food type lights
- d. – Clock / Duration / Food type display and key
- e. – Temperature / Food group key

- f. – Temperature / Weight display and key
- g. – Water shortage / Descaler lights
- h. – Water shortage / Descaler display and key
- i. – “+” and “-” keys
- j. – Start and Stop keys

## Description of Functions

Symbol	Function	Foods
	Steam	Cooking all sorts of vegetables, rice, cereals and meat. Extracting juice from berries. Simultaneous defrosting and cooking of vegetables.
	Regenerating & Sterilising	Regenerating plate dishes and ready-made meals. Sterilising/boiling down fruit.
	Cooking Vegetables	Cooking different types of vegetables.
	Cooking Fish	Cooking different types of fish.
	Cooking Meat	Cooking different types of meat.
	Side dishes	Cooking different types of side dishes.

## Basic settings

### Initial Settings

After your steam oven is first plugged in or after a power failure, the clock display will flash to indicate that the time shown is not correct.

The oven will not operate until the clock, the water hardness parameter and the Calibration is set.

To set the clock and the water hardness parameter value proceed as described in the following chapters.

### Setting the clock



To set the clock, proceed as follows:

1. Press the **Clock** key. The hour numbers will start to flash (not necessary if your Steam oven is first plugged in or after a power failure).
2. Press the “+” and “-” to set the correct hour value.
3. Press again the **Clock** key to set the minutes. The minute numbers will start to flash.
4. Press the “+” and “-” to set the correct minute value.
5. To finish, press the **Clock** key again.

### Hiding/ Displaying the Clock



If the clock display disturbs you, you can hide it by pressing the **Clock** setting key for 3 seconds. The dots that separate the hours and minutes will flash but the rest of the clock display will be hidden.

If you want to see the clock display again, press the **Clock** setting key again for 3 seconds.

### Water Hardness setting

The appliance features a system that automatically indicates when it is time to descale.

The system can be optimised for households with very soft water (also through using a water softening appliance) and very hard water, by changing the user settings to the relevant range of water hardness (see table below).

To set the water hardness parameter, proceed as follows:

1. Press the **Descal** key. The hardness number will start to flash on the Descal display (not necessary if your Steam oven is first plugged in or after a power failure).



## Basic settings

- Press the “+” and “-” to set the correct water hardness parameter value, according to the below table.
- Press the **Descale** key to set the parameter. The Descale display switches off.

Type	Water hardness				Display
	Ca + Mg (ppm)	English deg. [°eH]	French deg. [°dF]	German deg. [°dH]	
Soft water	0 to 150	0 to 11	0 to 15	0 to 8	SOFT
Medium water	151 to 350	12 to 25	16 to 35	9 to 20	MED
Hard water	351 to 500	26 to 35	36 to 50	21 to 28	HARD

## Safety blocking

The oven functioning can be blocked (for example, to stop it being used by children).



- To block the oven, press the **Stop** key for 3 seconds. You will hear a sound signal and the **display** will show the word “SAFE”. The oven is blocked in this state and cannot be used.
- To unblock the oven, press the **Stop** key again for 3 seconds. You will hear a sound signal and the **display** will show the time again.



## Timer

The timer functions like an egg timer. It can be used at any time and independently of all other functions.



To set the Timer proceed as follows:

1. Press the **Timer** key. The function key lights up and the Clock display starts blinking.
2. Press the “+” and “-” keys to set the Timer value.
3. Press the **Timer** key to validate. The Timer will start counting-down.

When the set time has elapsed the oven will emit three beeps that will be repeated every 30 seconds or until the **Timer** key is pressed.

While the Timer is running the Timer light is on. The display and lights show the following:

1. If there is no function running, the Clock display shows the Timer counting-down.
2. If there is an active function, the displays and lights show the normal function parameters. To check the Timer's remaining time press the Timer key. The Clock display will briefly show the Timer and resume the function indications after 10 seconds or once the Timer key is pressed again.

## Basic functions

### Steam function

**Use this function** to cook all sorts of vegetables, rice, cereals and meat. It is also suitable for extracting juice from berries and for simultaneous defrosting and cooking of vegetables.

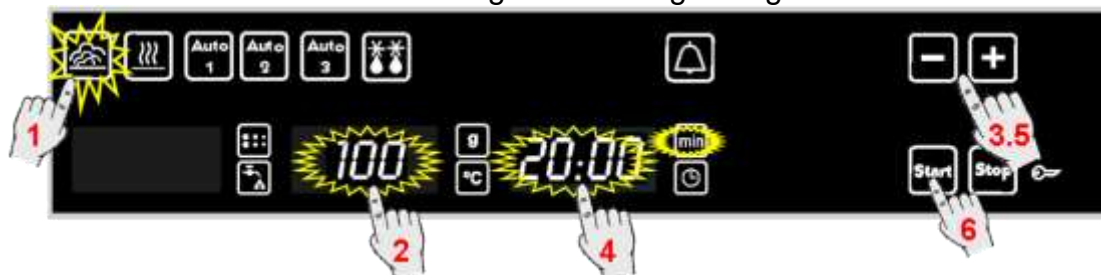

1. Press the **Steam Function** key. The function key lights up.
2. Press the **Temperature** key to set the desired value. The respective light will start to flash. If you do not press this key, the oven operates at 100 °C.
3. To change the Temperature press the “+” and “-” keys.
4. Press the **Duration** key to change the operating time. The respective light will start to flash. This setting is optional. Please jump to point 6 if you don't want to set duration.
5. Select the operating time you want by pressing the “+” and “-” (for example, to 20 minutes).
6. Press the **Start** key. The oven will start to operate.

### Regenerating & Sterilising

**Use this function** to regenerate plate dishes and ready-made meals as well as to sterilise and boil down fruit.



1. Press the **Regenerating Function** key. The function key lights up.
2. Press the **Food group** key to change the food type. The respective light will start to flash.
3. To change the Programme press the “+” and “-” keys, e.g. “r 01” (see following table).
4. Press the **Start** key. The oven will start to operate.

Function	Program	Food type	Temperature (°C)	Time (min)	Instructions
Regenerating	R 01	Plate dishes	100°C	13	Remove lid from container and put on rack.
	R 02	Ready-made meals / frozen	100°C	18	
Sterilising	R 03	Beans	100°C	35	The times and temperatures refer to 1L preserving jars.
	R 04	Cherries	80°C	35	
	R 05	Plums	90°C	35	
	R 06	Baby bottles and pacifiers	100°C	12	Put the (open) bottles and pacifiers on the perforated baking tray.

## Special Functions

### Cooking Vegetables – Auto 1

Use this function cook the vegetables described in the table below.



1. Press the **Auto 1 (Cooking Vegetables)** function key. The function key lights up.
2. Press the **Food group key** selection key to change the food type. The respective light will flash.
3. Press “+” and “-” keys to change the programme, e.g. “A 1” (see following table).
4. Press the **Start** key. The oven will start to operate.

The following table shows the Cooking Vegetables programmes, indicating weight intervals, and cooking and standing times (in order to ensure the food is of a uniform temperature).

Programme	Type of Vegetable	Temperature °C	Time (min)
A 1	Broccoli / florets	100°C	20
A 2	Cauliflower / florets	100°C	25
A 3	Potatoes / pieces	100°C	25
A 4	Snow peas	100°C	15
A 5	Asparagus	100°C	25

### Cooking Fish – Auto 2

Use this function cook the fish types described in the table below.



1. Press the **Auto 2 (Cooking Fish)** function key. The function key lights up.
2. Press the **Food group key** selection key to change the food type. The respective light will flash.
3. Press “+” and “-” keys to change the programme, e.g. “b 1” (see following table).
4. Press the **Start** key. The oven will start to operate.

The following table shows the Cooking Fish programmes, indicating weight intervals, and cooking and standing times (in order to ensure the food is of a uniform temperature).

Programme	Type of Fish	Temperature °C	Time (min)
b 1	Trout	80°C	20
b 2	Shrimp	90°C	15
b 3	Fish filet	80°C	18
b 4	Mussels	100°C	25
b 5	Lobster	100°C	30

## Special Functions

### Cooking Meat – Auto 3

Use this function cook the meat types described in the table below.



1. Press the **Auto 3 (Cooking Meat)** function key. The function key lights up.
2. Press the **Food group key** selection key to change the food type. The respective light will flash.
3. Press “+” and “-” keys to change the programme, e.g. “C 1” (see following table).

4. Press the **Start** key. The oven will start to operate.

The following table shows the Cooking Meat programmes, indicating weight intervals, and cooking and standing times (in order to ensure the food is of a uniform temperature).

Programme	Type of Meat	Temperature °C	Time (min)
C 1	Chicken breast	100 °C	30
C 2	Smoked pork loin / pieces	100 °C	45
C 3	Turkey escalope	100 °C	20
C 4	Pork filet, whole	100 °C	25
C 5	Vienna sausages	90 °C	15

### Cooking Side Dishes

Use this function cook the foods described in the table below.



1. Press the **Side Dishes** function key. The function key lights up.
2. Press the **Food group key** selection key to change the food type. The respective light will flash.
3. Press “+” and “-” keys to change the programme, e.g. “d 01” (see following table).

4. Press the **Start** key. The oven will start to operate.

The following table shows the **Side Dishes** programmes, indicating weight intervals, and cooking and standing times (in order to ensure the food is of a uniform temperature).

Programme	Type of Food	Temperature °C	Time (min)
d 1	Sweet yeast dumpling	100 °C	20
d 2	Yeast dumpling	100 °C	25
d 3	Napkin dumpling	100 °C	30
d 4	Rice	100 °C	35
d 5	Lentils	100 °C	40

## Water feeding

### Filling the water tank

All functions require the water tank to be full.

Fill the water tank with cold, fresh drinking water and introduce it into the slot located above the cavity (approximately 1L).

If the indication “rES” appears, it means that the water tank was not properly inserted.



### Refilling the water

The contents of the water tank normally suffice for one cooking session of 50-60 minutes.

If, however, the water tank needs to be refilled this is signalled by the message “- LD -” blinking, meaning that the water tank is empty.

**Warning! Only fill the water tank up to a maximum of 0.5 litres to ensure that the water does not overflow when it is pumped back to the water tank. RISK OF OVERFLOW.**

### Water tank message

When the water tank is removed or misplaced, the Water shortage display shows the message “rES”.



To clear the message, correctly insert the water tank.

### Emptying the water tank

When the appliance is switched off, the residual water is pumped back into the water tank.

While the water is being pumped the display shows “PUMP”.

This message stays on until the temperature of the water reaches 75° C before it can be pumped back to the water tank.

**Warning: the water in the tank may be hot. Danger of burns!**

After the water is pumped back to the water tank, the display will show the message “DEP” requiring the following actions:

1. Remove and empty the water tank.
2. Dry the water tank and introduce it back into the slot located above the cavity. Clean and dry the cooking space.
3. Leave the appliance door open so that the cooking space can cool down and dry completely.

**IMPORTANT NOTE: It is advisable to remove the water tank and empty it after a cooking cycle. This prevents the formation of bacteria and limestone inside the appliance.**

If the water tank has not been removed from the oven and a new cooking cycle is started, the oven displays the warning “DEP”.

This warning can be cleared by pressing the **Stop** key and proceed with the new cooking cycle without removing and emptying the water tank.

## When the oven is working...

### Interrupting a cooking cycle

You can stop the cooking process at any time by pressing the **Stop** key once.

The oven incorporates a steam-reduction function that is activated when the **Stop** key is pressed to gradually release the steam from the cavity, so that there is no sudden rush of steam when the appliance door is opened.

This function takes around 3 minutes and during it the display shows the word "VAP".

**Warning! When opening the door during or upon completion of the cooking cycle, be careful of the flow of hot air and/or steam coming out of the cooking chamber. Step back or to the side to avoid burns.**

At this point:

- The steam generation is interrupted.
- The cavity walls and the water tank are still very hot. **Danger of burning!**
- The timer stops and the display shows the remaining operating time (if this has been set).

If you wish, at this point you can:

1. Turn or stir the food to ensure it will be evenly cooked.
2. Change the cooking parameters.

To restart the process, close the door and press the **Start** key.

### Altering parameters

The operating parameters (time and temperature) can only be altered when the cooking process has been interrupted by proceeding as follows:

1. To alter the time, press "+" and "-" keys. The new time defined is immediately valid.
2. To alter the temperature, press the Temperature Selection key and the display and respective light start to flash. Alter the parameter by pressing the "+" and "-" keys and confirm by pressing the Temperature Selection key again.

### Cancelling a cooking cycle

If you wish to cancel the cooking process, press the **Stop** key twice.

You will then hear 3 beeps and the message "End" will appear on the **display**.

### End of a cooking cycle

At the end of the set duration or when you press the **Stop** key to finish the cooking cycle the oven starts the steam-reduction function.

This function gradually releases the steam from the cavity, so that there is no sudden rush of steam when the appliance door is opened.

This function takes around 3 minutes and during it the display shows the word "VAP".

At the end of this process you will hear three beeps and the display will show the word "End".

**Warning! When opening the door during or upon completion of the cooking cycle, be careful of the flow of hot air and/or steam coming out of the cooking chamber. Step back or to the side to avoid burns.**

The beeps are repeated every 30 seconds until the door is opened or the **Stop** key is pressed.

The cooling fan can continue to run for a certain length of time after the appliance has been switched off. This is a normal function that is meant to reduce the temperature inside the oven.

When the display shows the word "DEP", this means that the water was pumped and that the water tank can be removed.

Remove the water tank and dry it thoroughly. Let the cooking space cool down for a moment and then clean and dry it with a cloth. The door should be left open for some time so that the appliance can dry completely.

## When the oven is working...

### Steam Flow

It is normal to have an intermittent steam flow, coming out from the oven front.

This is especially noticeable in winter time or in high moisture environments.

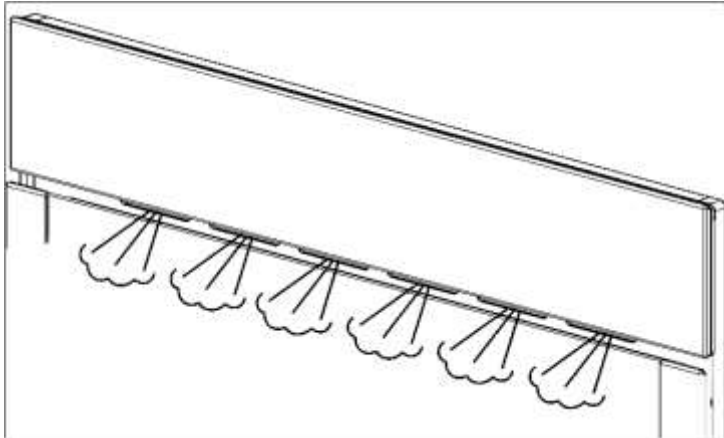

### Residual water in the oven

To reduce the residual water in the oven, it is recommended to insert a tray in the bottom rack level. The condensation released from the food begins to drip on the tray. The remaining residual water can be easily dried with a cloth.



## Usage, tables and tips

### Use of accessories

The perforated container is suitable for cooking fresh or deep frozen vegetables, meat and poultry. In this case it is important that the non-perforated container is introduced into the first level. This way, dripping liquids are collected and the appliance does not get dirty. The perforated container with the food should be inserted into the second level.

The non-perforated container is used to steam sensitive foods, e.g. compotes and dumplings.

The rack is used when cooking with small containers, as for example, dessert bowls and to regenerate plate dishes.

For more precise information refer to the tables.

The suggested times and temperatures are guideline values. The actual cooking time can vary according to the type and quality of the foods.

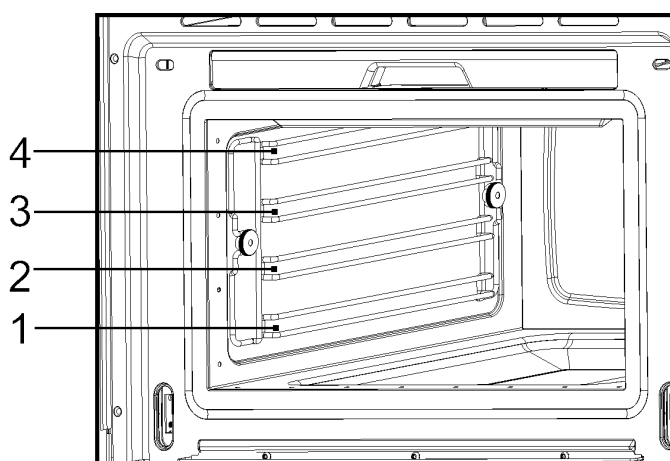

### Fish

Fish	Quantity	Temperature °C	Time min.	Container	Level
Gilthead sea bream	800-1200 g	80	30-40	Perforated	2
Trout	4 x 250 g	80	20-25	Perforated	2
Salmon filet	500-1000 g	80	15-25	Perforated	2
Salmon trout	1000-1200 g	80	25-35	Perforated	1/2
King prawns	500-1000 g	80	15-20	Perforated	2
Green-shell mussel	1000-1500 g	100	25-35	Perforated	2
Halibut filet	500-1000 g	80	20-25	Perforated	2
Cockles	500-1000 g	100	10-20	Perforated	2
Lobster	800-1200 g	100	25-30	Perforated	1/2
Cod filet	1000-1200 g	80	20-25	Perforated	2
Blue mussel	1000-1200 g	100	15-25	Perforated	2
Lake trout	4 x 250 g	80	25-30	Perforated	2
Haddock	1000-1200 g	80	20-25	Perforated	2
Tuna filet	500-1000 g	80	15-20	Perforated	2
Pike perch	4 x 250 g	80	25-30	Perforated	2

## Usage, tables and tips

### Meat

Meat	Quantity	Temperature °C	Time min.	Container	Level
Chicken leg	4-10	100	40-45	Perforated	2
Chicken breast	4-6	100	25-35	Perforated	2
Smoked pork loin	500g – 1000 g	100	40-50	Perforated	2
Turkey escalope	4-8	100	20-25	Perforated	2
Pork filet, whole	4-8	100	20-30	Perforated	2
Sausages		80-100	10-15	Perforated	2

### Eggs

Eggs	Temperature °C	Time min.	Container	Level
Eggs in Glass	100	10-15	Rack	2
Eggs, hard	100	15	Rack	2
Eggs, soft	100	10-12	Rack	2

### Side dishes

Side dishes	Quantity	Temperature °C	Time min.	Container	Level
Pearl barley + Liquid	200g + 400 ml	100	30-35	Rack, glass bowl	2
Semolina + Liquid	200g + 300 ml	100	10-20	Rack, glass bowl	2
Lentils + Liquid	200g + 375 ml	100	20-50	Rack, glass bowl	2
Rice + Liquid	200g + 250 ml	100	25-40	Rack, glass bowl	2

## Usage, tables and tips

### Vegetables

Vegetables		Temperature °C	Time min.	Container	Level
Eggplant/Aubergine	in slices	100	15-20	Perforated	2
Beans		100	35-45	Perforated	2
Broccoli	florets with stalk	100	25-30	Perforated	2
Broccoli	florets without stalk	100	15-20	Perforated	2
Cauliflower	florets	100	25-30	Perforated	2
Cauliflower	whole head	100	40-45	Perforated	1
Peas		100	30-35	Perforated	2
Fennel	in stripes	100	15-20	Perforated	2
Fennel	cut in half	100	20-30	Perforated	2
Potatoes with skin	whole, very small	100	20-25	Perforated	2
Potatoes with skin	whole, very big	100	45-50	Perforated	2
Potatoes without skin	in pieces	100	20-25	Perforated	2
Turnip	in sticks	100	20-25	Perforated	2
Snow peas		100	15-20	Perforated	2
Carrots	in slices	100	25-30	Perforated	2
Corn cobs		100	50-60	Perforated	2
Bell peppers	in stripes	100	12-15	Perforated	2
Hot pepper		100	12-15	Perforated	2
Mushrooms	in quarters	100	12-15	Perforated	2
Leeks	in slices	100	10-12	Perforated	2
Brussels sprouts		100	25-35	Perforated	2
Celery	in stripes	100	15-20	Perforated	2
Asparagus		100	20-35	Perforated	2
Spinach		100	12-15	Perforated	2
Celery stalks		100	25-30	Perforated	2
Courgette	in slices	100	12-18	Perforated	2

### Dumplings

Dumplings	Temperature °C	Time min.	Container	Level
Sweet dumpling	100	20-30	Not perforated	2
Sweet yeast dumpling	100	15-20	Not perforated	2
Yeast dumpling	100	15-25	Not perforated	2
Bread dumpling	100	20-25	Not perforated	2
Napkin dumpling	100	25-30	Not perforated	2

## Usage, tables and tips

### Desserts

Desserts	Quantity	Temperature °C	Time min.	Container	Level
Stewed apples	500-1500 g	100	15-25	Not perforated	2
Stewed pears	500-1500 g	100	25-30	Not perforated	2
Crème brûlée		80	20-25	Rack - bowl	2
Crème caramel		80	25-30	Rack - bowl	2
Yogurt		40	4-6 hrs.	Rack - bowl	2
Stewed peaches	500-1500 g	100	15-20	Not perforated	2

### Fruit (Sterilising/Boiling down)

Fruit	Quantity	Temperature °C	Time min.	Container	Level
Pears	4-6 1l glasses	100	30-35	Rack	1
Cherries	4-6 1l glasses	80	30-35	Rack	1
Peaches	4-6 1l glasses	80	30-35	Rack	1
Plums	4-6 1l glasses	80	30-35	Rack	1

### Regenerate

Warming-up	Quantity	Temperature °C	Time min.	Container	Level
Plate dishes	1-2	100	12-15	Rack	2
Plate dishes	3-4	100	15-20	Rack	2
Ready-made meals		100	15-20	Rack	2

### Blanch

Vegetables	Quantity	Temperature °C	Time min.	Container	Level
e.g. Beans, Leek		100	10-12	Perforated	2
Curly Kale	1000-2000 g	100	12-16	Perforated	2
Savoy cabbage	10-20	100	12-15	Perforated	2
White cabbage, whole	2000-2500 g	100	30-45	Perforated	1
Tomatoes, peeled		80	12	Rack	2

## Usage, tables and tips

### Defrost

Vegetables / Side dish		Temperature °C	Time min.	Container	Level
Broccoli	florets with stalk	100	15-20	Perforated	2
Mixed vegetables		100	15-20	Perforated	2
Spinach leaves	portions	100	10-15	Not perforated	2
Cauliflower	florets	100	15-20	Perforated	2
Peas		100	15-25	Perforated	2
Curly kale	bigger portion	100	25-35	Not perforated	2
Carrots	in slices	100	15-20	Perforated	2
Brussels sprouts		100	20-25	Perforated	2
Asparagus		100	25-30	Perforated	2
Ready-made meals		100	as required	Rack	2
Bread		100	10-25	Rack	2
Rice		100	15-25	Not perforated	2
Lentils		100	15-20	Not perforated	2
Noodles		100	15-20	Not perforated	2

### Two level cooking

#### Some suggestions:

When cooking with two levels the grill always belongs to the 2nd or 3rd level of insertion from the bottom to the top.

This way the usual vessels of porcelain, Jena glass or of stainless steel can be put inside the oven.

The container of cooking perforated or not, will be inserted in the 1st level from the bottom. It can also be cooked with two grills.

Different cooking times are controlled this way:

Foods that need a longer cooking time should be placed in the upper area of the oven. Foods with a shorter cooking time should be placed on the 1<sup>st</sup> level.

#### One example: Vegetables, potatoes and fish.

Place the vegetables and potatoes in any suitable container on the rack inserted in the 2<sup>nd</sup> or 3<sup>rd</sup> level.

Insert the fish in the 1<sup>st</sup> level.

When using the perforated tray to cook fish, the non-perforated tray must be inserted in the bottom of the appliance to collect liquid dripping from the fish. This way the appliance is kept clean.

Time: Vegetables and potatoes 25-35 Min.

Time: Fish – depending on type – 15-25 Min.

Select the longest cooking time. Because of the different levels the food is ready at the same time, without any over cooking.

### Cleaning the cooking space

Avoid using abrasive cleaners such as scouring pads, steel wool, etc. as they can damage the surface.

Wipe the cooking space clean using a damp cloth whilst the appliance is still warm. Finish off by drying the cooking space.

For ease of cleaning, the shelf guides can be removed (see the following chapter).

### Removing the shelf guides

Unscrew and remove the knurled nuts 1 in the front of the shelf guides in an anti-clockwise direction.

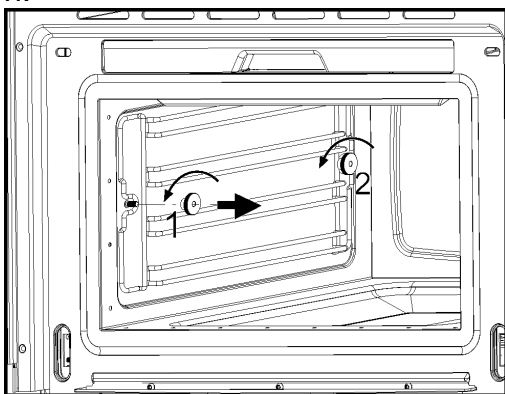

Unscrew and loosen the knurled nuts 2 in the back of the shelf guides in an anti-clockwise direction. Do not completely remove these nuts.

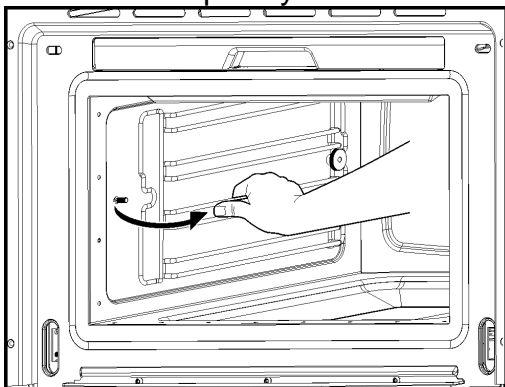

Pull the shelf guides to the inside of the cavity and remove from the front.

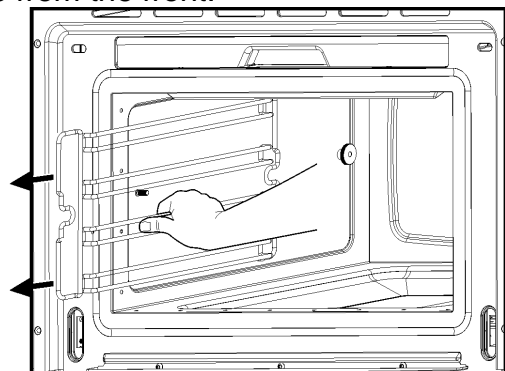

To put them back, insert the shelf guides into the knurled nuts 2 in the back and position on the

screws in the front. Screw the knurled nuts 1 and 2 in a clockwise direction till tight.

### Removing the appliance door

1. Open the appliance door as far as it will go.

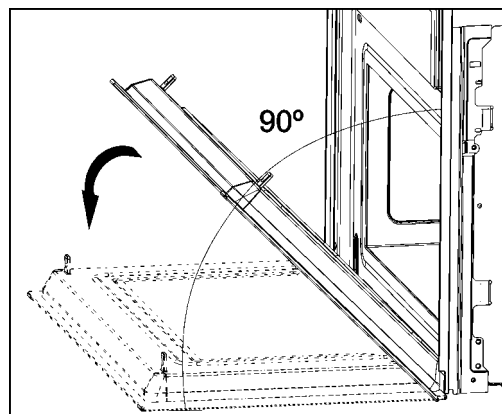

2. Insert 2 pins inside the holes in the hinges.

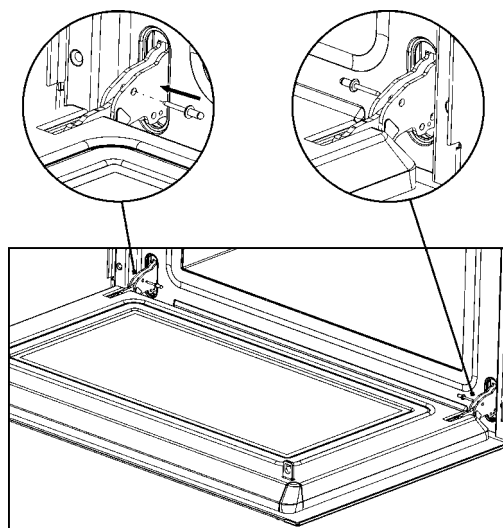

3. Close the appliance door just enough that it can be lifted out.

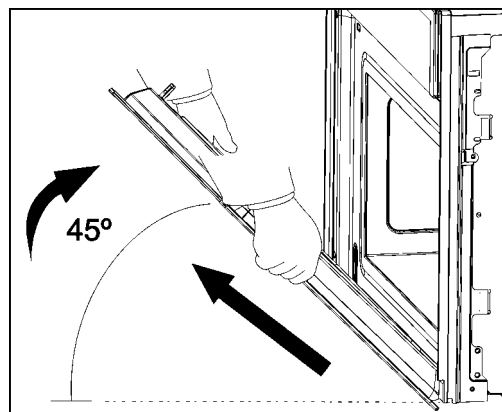

4. To reassemble, push the hinges into the holes from the front.

5. Open the appliance door as far as it will go and remove the pins.

## Care and maintenance

### Descaling

Whenever steam is produced, irrespective of the hardness of the local water supply (i.e. the limescale content of the water), limescale is deposited inside the steam generator.

The time interval between descaling depends on the hardness of the water and frequency of use. If steaming 4x30 minutes per week, the appliance must be descaled (depending on water hardness) roughly as follows:

Water hardness	Descal after about
Very soft	18 months
Medium	9 months
Very hard	6 months

The appliance automatically detects when descaling is necessary and when this happens the Descal light stays on. If the Descaling procedure is not performed, some cooking cycles after the Descal light starts to flash. If once again the Descaling procedure is not performed, some cooking cycles after the oven functioning is blocked, the Descal light stays on and the display shows "CAL" blinking.

**IMPORTANT NOTE: Failure to descale the appliance will likely impair the functioning of or cause damage to the appliance.**

### Suitable descaling solutions

For descaling, use the descaling solution "durgol®".

This solution allows a professional and careful descaling of your appliance. Available at Customer Care Centres.

**Warning! Do not use vinegar or vinegar-based products as they can cause damage to the oven's internal circuit.**

Traditional descaling solutions are not appropriate because they can contain foaming agents.

## Descaling procedure



**Warning: For safety reasons, the descaling process cannot be interrupted.**

The appliance can be descaled with the appliance door open or closed. The appliance must be in idle state prior to starting the descaling cycle.

To run a descaling cycle proceed as follows:

1. Press the **Descal** key. The display shows “**CAL**” and there is an intermittent beep.

(In case you want to run the descaling cycle prior to the oven's warnings, press the **Descal** key and the **Duration** key simultaneously for 5 seconds).

2. Press the **Start** key.
3. When the display shows “**0.5L**”, remove the water tank.
4. Pour 0.5 litres of an adequate descaling solution into the water tank and put the water tank back.
5. Press the **Start** key. The Descal cycle is initiated and takes about 30 minutes.

6. When the Descal display shows “**1.0L**” flashing and the oven emits a beep, remove and empty the water tank.
7. Fill the water tank with 1.0 litres of cold water and put the water tank back.
8. Press the **Start** key. The first rinsing cycle starts.
9. When the Descal display shows again “**1.0L**” flashing and the oven emits a new beep, remove and empty the water tank.
10. Fill the water tank with 1.0 litres of cold water and put the water tank back.
12. Press the **Start** key. The second rinsing cycle starts.
13. When the rinsing cycle has finished the display shows “**End**”.
14. Remove, empty and dry the water tank.



## Oven cleaning

**Warning!** Cleaning should be done with the oven power switched off. Take the plug out of the socket or switch off the oven's power circuit.

**Do not use aggressive or abrasive cleaning products, scourers that scratch surfaces or sharp objects, since stains may appear.**

**Do not use high pressure or steam jet cleaning appliances.**

### Front surface

Normally you just need to clean the oven with a damp cloth. If it is very dirty, add a few drops of dishwashing liquid to the cleaning water. Afterwards, wipe the oven with a dry cloth.

**In an oven with an aluminium front,** use a mild glass cleaning product and a soft cloth that does not release any fibres or threads. Wipe from side to side without exerting any pressure on the surface.

Immediately remove limescale, fat, starch or egg white stains. Corrosion can occur under these stains.

Do not let any water get inside the oven.

### Oven interior

After use, remove any water on the bottom of the cooking space with a soft cloth. Leave the appliance door open so that the cooking space can cool down.

To remove dirt that is harder to shift, use a non-aggressive cleaning product. **Do not use oven sprays or other aggressive or abrasive cleaning products.**

**Always keep the door and the oven front very clean to ensure that the door opens and closes properly.**

Make sure water does not enter the oven ventilation holes.

The glass lamp cover is located on the oven ceiling and can be removed easily for cleaning. For this you just need to unscrew it and clean it with water and dishwashing liquid.

### Accessories

Clean the accessories after each use. If they are very dirty, soak them first of all and then use a brush and sponge. The accessories can be washed in a dish washing machine.

## What should I do if the oven doesn't work?

**WARNING!** Any type of repair must only be done by a specialised technician. Any repair done by a person not authorised by the manufacturer is dangerous.

You do not need to contact Technical Assistance to resolve the following questions:

- **The display is not showing!** Check if:
  - The time indication has been switched off (see section on Basic Settings).
- **Nothing happens when I press the keys!** Check if:
  - The Safety Block is active (see section on Basic Settings).
- **The oven does not work!** Check if:
  - The plug is correctly fitted in the socket.
  - The oven's power is switched on.
- **When the oven is operating I can hear some strange noises!** This is not a problem.
  - It has to do with the operating noises that can occur during the cooking process, e.g. by the water pumps in the steam generator.
  - The steam inside the cavity produces a pressure build-up and sometimes the cavity walls may produce noise when they react to the pressure.
  - These noises are normal, there is no problem.
- **The food doesn't heat up or heats very slowly!** Check if:
  - You have selected the correct operating times and temperature setting.
  - The food you have put inside the oven is a larger amount or colder than you usually put in.
- **If the message "Err\_" appears in the display, please contact the Customer Care.**

- **The appliance still makes a noise after the cooking process is finished!** This is not a problem.
  - The cooling fan keeps on working for some time. When the temperature has dropped sufficiently, the fan will switch itself off.
- **The oven switches on but the interior light does not go on!**
  - If all the functions work properly it is probable that the lamp has blown. You can keep on using the oven.

### Replacing the light bulb

To replace the light bulb, proceed as follows:

- Disconnect the oven from the power supply. Take the plug out of the socket or switch off the oven's power circuit.
- Unscrew and remove the glass light cover **(1)**.
- Remove the light bulb **(2)**. Warning! **The bulb may be very hot.**
- Fit a new G9 230/ 25W halogen bulb. Follow the lamp manufacturer's instructions.
- Screw the glass light cover into place **(1)**.
- Connect the oven again to the power supply.

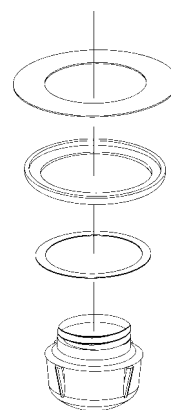

# Technical characteristics

## Displays

Displays			Description
Display 1	Display 2	Display 3	
<b>Descaling</b>			
1		(clock)	Soft water.
2	---		Medium water.
3	---		Hard water.
CAL	---		Appliance must be descaled.
0.6L	---	(clock)	Flashing – descaling starts.
1.0L	---	(clock)	Feed 0.6 litre descaling solution into the water tank.
			Feed 1 litre cold water into the water tank for rinsing.
<b>Water shortage</b>			
-LO-	---	(Clock or time setting)	Insufficient water in water tank.
<b>Water tank</b>			
rES	---/(Temperature or foodstuff group)	(Clock or time setting)	Indication that water tank is missing.
dEP	---	(Clock)	The water tank must be removed, emptied and reinserted.
<b>Special functions</b>			
---	A1 to A5	(Time setting)	Special functions with predefined temperatures and times.
	b1 to b5		
	c1 to c5		
	d1 to d5		
	r1 to r5		
<b>Steam reduction</b>			
VAP	---	(Clock)	Indication that steam reduction process is ongoing.
PUMP	---	(Clock)	Indication that cold water is entering the boiler and hot water is being pumped to the water tank.
FULL	---	(Clock)	The water tank must be removed, emptied and reinserted.
<b>System warnings</b>			
---	LAMP	(Clock)	Damaged lamp.
---	HOT	(Clock)	Temperature in the PCB is too high.
---	Err_	(Clock)	Contact the Customer Service

## Specifications

- AC Voltage ..... (see characteristics plate)
- Power required ..... 1500 W
- Exterior dimensions (W×H×D) ..... 595 × 455 × 472 mm
- Interior dimensions (W×H×D) ..... 420 × 210 × 390 mm
- Oven capacity. .... 35 l
- Weight ..... 32 kg

## Environmental protection

### Disposal of the packaging



The packaging bears the Green Dot mark.

Dispose of all the packaging materials such as cardboard, expanded polystyrene and plastic wrapping in the appropriate bins. In this way you can be sure that the packaging materials will be re-used. Keep all packaging away from small children as it may present suffocation/choking hazard.

### Disposal of equipment no longer used



According to European Directive 2012/19/EU on the management of waste electrical and electronic equipment (WEEE), home electrical appliances

should not be put into the normal systems for disposal of solid urban waste.

Outdated appliances should be collected separately to optimise component material recovery and recycling rates and to prevent potential harm to human health and the environment. The symbol of a rubbish container superimposed by a diagonal cross should be put on all such products to remind people of their obligation to have such items collected separately.

Consumers should contact their local authorities or point of sale and request information on the appropriate places to leave their old home electrical appliances.

Before disposing of your appliance, render it non-usable by pulling out the power cable, cutting it off and disposing of it.

## Installation instructions

### Before installation

**Check that the input voltage** indicated on the characteristics plate is the same as the voltage of the power outlet you are going to use.

Open the oven door and **take out all the accessories** and remove the packing material.

**Warning!** The front surface of the oven may be covered in a **protective film**. Before using the oven for the first time, carefully remove this film, starting on the inside.

**Make sure that the oven is not damaged in any way.** Check that the oven door closes correctly and that the interior of the door and the front of the oven opening are not damaged. If you find any damage contact our Customer Care Centre on the number supplied on the back cover of this handbook.

**DO NOT USE THE OVEN** if the power cable or the plug is damaged, if the oven does not function correctly or if it has been damaged or dropped. Contact our Customer Care Centre on the number supplied on the back cover of this handbook.

Put the oven on a flat and stable surface. The oven must not be installed close to any sources of heat, radios or televisions.

**During installation, make sure that the power cable does not come into contact with any moisture or objects with sharp edges and the back of the oven. High temperatures can damage the cable.**

**Warning: after the oven is installed you must make sure you can access the plug.**

### After installation

The oven is equipped with a power cable and a plug for single phase (household) current, 230-240V ~ 50Hz.

**If the oven is to be installed on a permanent basis** it must be installed by a qualified technician. In such a case, the oven should be connected to a circuit with an all-pole circuit breaker with a minimum separation of 3 mm between contacts.

**WARNING: THE OVEN MUST BE EARTHED.**

**The manufacturer and retailers do not accept responsibility** for any damage that may be caused to persons, animals or property if these installation instructions are not observed.

**The oven only functions** when the door is closed correctly.

Before the first use, clean the inside of the oven and the accessories, following the cleaning instructions given in the "Oven cleaning" section.

**During installation, follow the instructions supplied separately.**

## Installation / Encastrement / Installatie

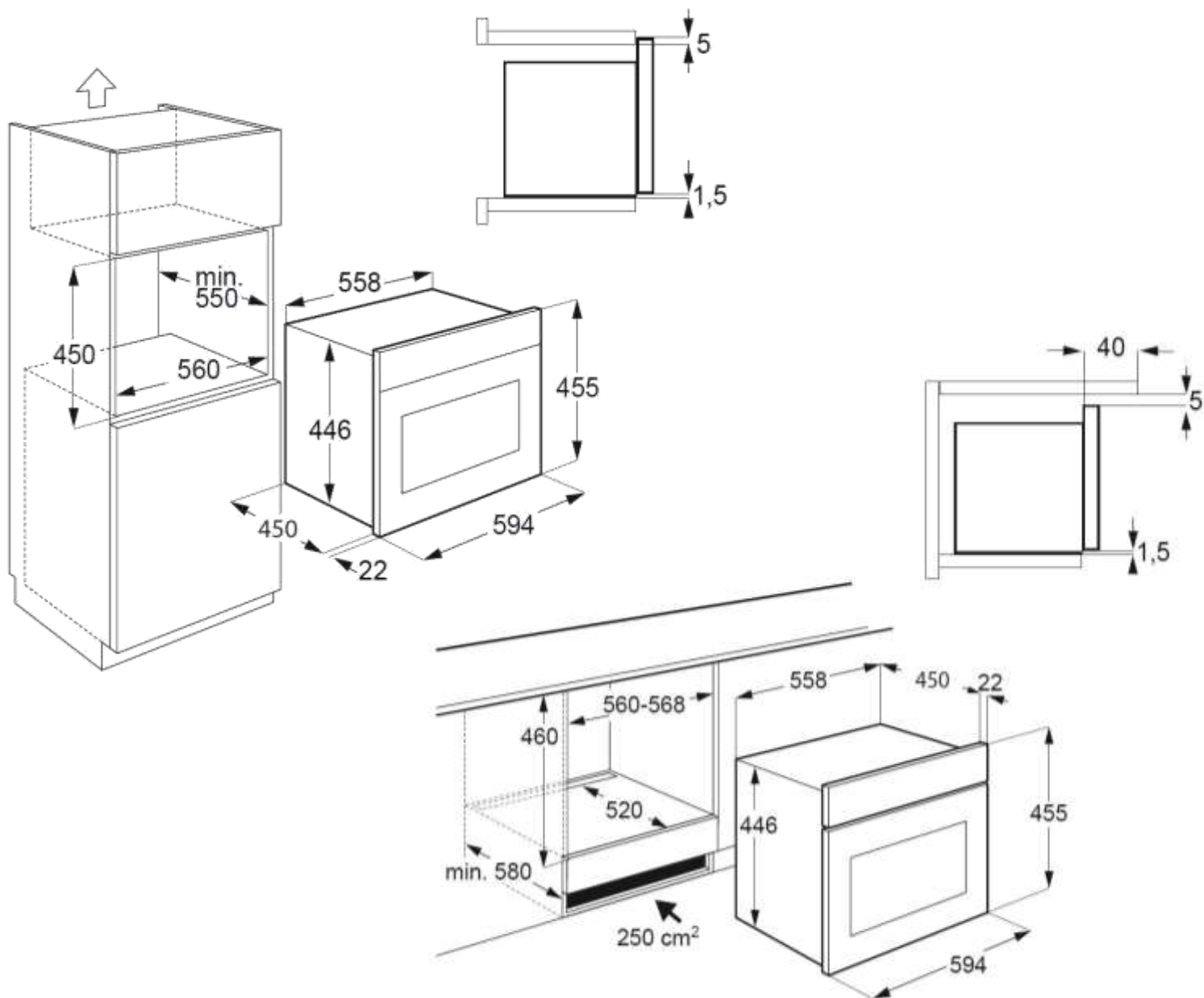

### EN

- Push oven completely into the cabinet and centre it.
- Open door and fasten the appliance to the cabinet using the four screws provided. Insert the screws through the front holes.

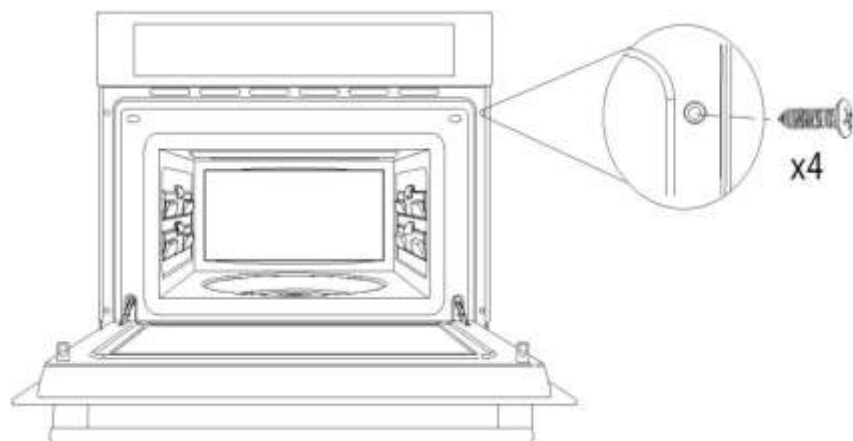



Global Website

[www.fujioh.com](http://www.fujioh.com)

**FUJIOH INTERNATIONAL TRADING PTE.LTD.**

Southeast Asia Regional Headquarters

130 Joo Seng Road #05-05 Singapore 368357

Tel : (65) 6286 3286 Fax : (65) 6285 3285

E-mail : [fit@fujioh.com.sg](mailto:fit@fujioh.com.sg)