

# HOOD/ FR-FS1890



## OIL TECH Cooker Hood

小さなサイズで、  
大きな性能。



**3** COOKER HOOD  
LIMITED WARRANTY\*

### Small in size, big on performance

This ultra-thin hood is deceptively tough on oil to stop build-up on your kitchen surfaces.

Three aesthetically gorgeous finishes means there's the perfect Slim Oil Tech cooker hood for your interior design. Especially designed for the Asian kitchen, it captures your cooking fumes and filters the oil into the oil tray for easy removal and cleaning. Technically advanced, it doesn't have to be big to be powerful.



# -FUJIOH-

## ADVANCE FUNCTION

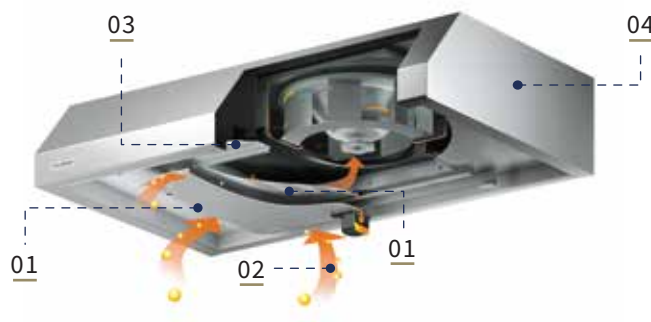

### 01/ Easy Cleaning

#### Oil Repellent Paint

- Oil repellent paint is processed on surfaces
- Easy to wipe and clean

Normal Metal      Oil Repellent

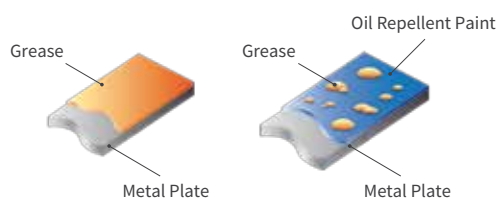

#### Aqua Slit Filter

- Hydrophilic Coating
- The filter can be easily washed with only water



### 02/ High Oil Capturing Ratio

- Over 83% oil capturing ratio (recycling type)



The Fujioh OIL TECH Cooker Hood is specially designed for the heavy and oily Asian cooking in mind. As the fumes are captured, the oil separation process integrated in our Fujioh technology filtrates the fumes into oil, and into the oil tray with the help of the rectifier panel and aqua slit filter. Each OIL TECH component helps improve your quality of life in the kitchen.

### 03/ Eco LED Lighting

### 04/ Slim Design

- Easy to install
- Only 180mm high

\*3 years warranty for motor • 1 year warranty for other parts  
Warranty Terms and Conditions apply

## COLORS



SM/ Silver Metallic



W/ White



RS/ Rich Silver

\*Product images are for illustrative purposes only and may differ from the actual product.

## INSTALLATIONS

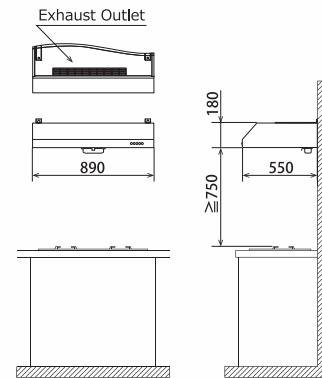

FR-FS1890R (Recycling) [mm]

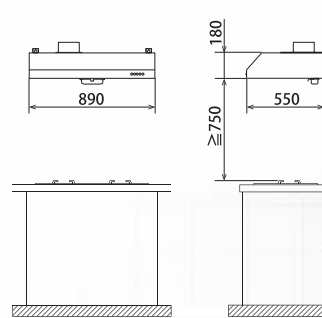

FR-FS1890V (Ventilating) [mm]

\*This model has "under cabinet type" only.

\*Width of this model is 890 only.

## SPECIFICATIONS

Type	FR-FS1890R (RECYCLING)	FR-FS1890V (VENTILATING)
Dimensions [mm]	W890 x D550 x H180	
Weight [kg]	20	21
Power Consumption [W] (220/230/240V)	92/97/103	92/97/103
Voltage [V/Hz]	220, 230, 240/50	
Duct Diameter [mm]	Φ150	
Air Flow [m <sup>3</sup> /h] (220/230/240V)	500/505/510	500/505/510
Sound Level [dB] (220/230/240V)	56/57/57	57/58/59
Oil Capturing Ratio [%]	83	81
Switch	Mechanical Push Button	
Speed	3 Speed	
Hood Body	Oil repellent paint	
Rectifier Panel	Oil repellent paint	
Filter	Aqua Slit Filter (Hydrophilic Coating)	
Oil Tray	Oil repellent paint	
Lighting	LED 3.5W x 1	

\*All specification are based on stringent in-house test results conducted in Fuji Industrial Co. Ltd, Japan

