

HOOD/ FR-MT1990

楽しい料理の、
強い味方。

3 COOKER HOOD
LIMITED WARRANTY*
YEARS



Cooking will never be a hassle again

Our cooking hood not only adds value, but it compliments well with your gas hob not only aesthetically but functionally as well. The spectacular improvement on its oil capturing ratio, sets a bar higher in ensuring that your kitchen will remain spick and span even while you are whipping up marvellous dishes. Leaving your kitchen with a cleaner and fresher aftermath!

-FUJIOH-

ADVANCED FUNCTIONS

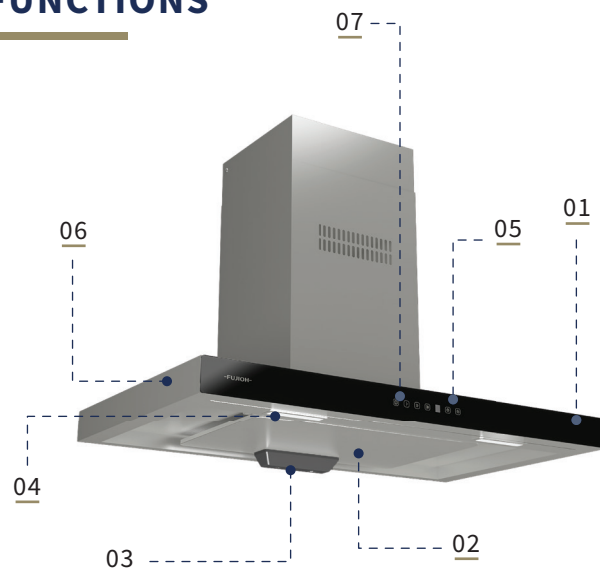

01/ Glossy Glass Panel with
Touch Control

02/ Easy Cleaning

Aqua Slit Filter

- Hydrophilic Coating
- The filter can be easily washed with only water



03/ High Oil Capturing Ratio with
rectifier panel and oil tray

- 94% oil capturing ratio (recycling type)

04/ Eco LED Lighting

05/ Timer

- 3/6/9 mins

06/ Rust Resistant Material

- All stainless parts at exterior are SUS304

07/ Safety Feature

- Auto stop after 5 hours of non-stop operation period

*3 years warranty for motor • 1 year warranty for other parts
Warranty Terms and Conditions apply

COLORS



GBK/ Glass Black



GCM/ Glass Champagne Metallic

*Product images are for illustrative purposes only and may differ from the actual product.

INSTALLATIONS

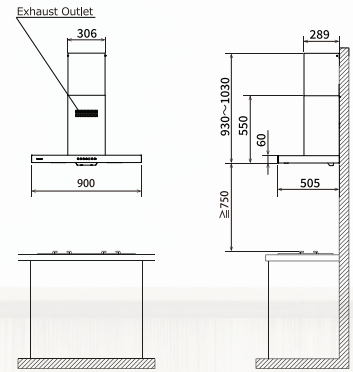

FR-MT1990R (Recycling) [mm]

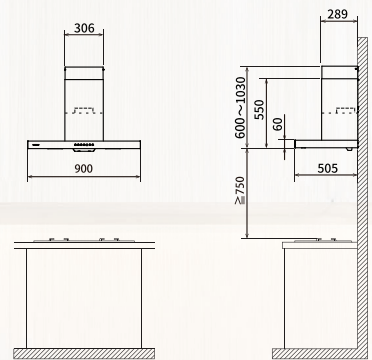

FR-MT1990V (Ventilating) [mm]

SPECIFICATIONS

Type	FR-MT1990R (RECYCLING)	FR-MT1990V (VENTILATING)
Dimensions [mm]	W900 x D505 x H930~1030	W900 x D505 x H600~1030
Weight [kg]	17.8	16.5
Power Consumption [W] (220/230/240V)	126/134/143	195/211/226
Voltage (V/Hz)	220-240/50	
Duct Diameter [mm]	-	Φ150
Sound Level [dB] (220/230/240V)	56/56/57	50/51/52
Oil Capturing Ratio [%]	94	84
Switch	Touch Switch	
Speed	3 Speeds	
Timer	3/6/9 mins	
Hood Body	SUS304	
Rectifier Panel	SUS304	
Filter	Aqua Slit Filter (Hydrophilic Coating)	
Lighting	LED 1.5W x 2	

*All specification are based on stringent in-house test results conducted in Fuji Industrial Co. Ltd, Japan

Revision Date : 11/2020

