

# WATER HEATER/ FZ-WH50

WAVE SERIES

さざ波シリーズ

**5** YEARS WATER HEATER LIMITED WARRANTY\*



## A hassle-free water heater

Manufactured to enable personal control of the shower temperature by a turn of the control while allowing you to beat the unbearable climate swings.

Enjoy silent operation, powerful flow and experience a new degree of comfort while showering. Your shower experience will never be the same!

**-FUJIOH-**

## FEATURES

### 01/ Performance



**90° Stop Valve with Built-in Filter**  
Enjoy higher water flow rate and cleaner water



**Stepless Power Control**  
Shower at your ideal shower temperature



**Maintenance-free with Brushless Design\***  
No carbon brush to change and enjoy cleaner water



**Silent Operation\***  
Silent operation using DC pump versus AC pump



**Powerful Flow\***  
Deliver powerful flow yet save up to 70% energy

(\*For models with Brushless DC Silent Inverter Pump only)

### 02/ Safety



**Fire Retardant Heater Tank**  
Peace of mind with fire retardant VO material that complies to UL-94 grade



**Auto Flow Sensor Switch**  
Avoid dry burn by shutting off heater when water flow is too low



**Double Function Thermostat**  
Auto reset thermostat when water temperature exceeds safe limit



**Anti-Leak Water Tank**  
Avoid scalding by withstanding water with high pressure



**IP25 Splash Proof Protection**  
Protect against water and dust



**Insulated PVC Hose**  
Extra safety with insulated PVC hose and non-conductive stop valve

### 03/ Comfort



**180° Swivel Diverter Spout^**  
3-in-1 spout with swivelable diverter for extra convenience



**Adjustable Rain Shower Height^**  
Extendable by 1 feet to bath at your preferred height

(^For models with Rain Shower Set only)

## 5 MULTI SPRAY HANDSHOWER WITH ANTI-TWIST HOSE#

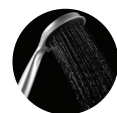

01/ Comfort



02/ Maxi



03/ Combo



04/ Misty



05/ Massage

\*5 years warranty for heating element • 1 year warranty for other parts  
Warranty Terms and Conditions apply

# For selected models

## COLORS

### 01/ Hand Shower Set Type



**BK/** Black (Matt)



**W/** White (Glossy)

### 02/ Rain Shower Set Type



**BK/** Black (Matt)



**W/** White (Glossy)

## INSTALLATIONS

### 01/ Hand Shower Set Type

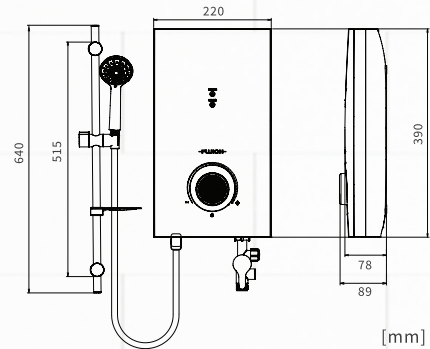

[mm]

### 02/ Rain Shower Set Type

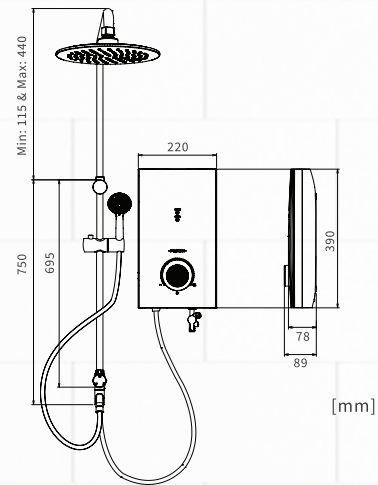

[mm]

## SPECIFICATIONS

Model Name	FZ-WH5033N	FZ-WH5033D	FZ-WH5033NR	FZ-WH5033DR
<b>Equipment</b>				
Water Connection [mm/inch BSP]	15 or 1/2	15 or 1/2	15 or 1/2	15 or 1/2
Brushless DC Silent Inverter Pump	No	Yes	No	Yes
180° Swivel Divert Spout	No	No	Yes	Yes
Adjustable Rain Shower Height	No	No	Yes	Yes
<b>Performance</b>				
Minimum Water Flow Rate [Liter/min]	2	2	2	2
Maximum Water Pressure [kPa]	380	380	380	380
Minimum Water Pressure [kPa]	20	20	20	20
<b>Power, Voltage</b>				
Voltage [V/Hz]	230/50	230/50	230/50	230/50
Available Power [kW]	3.3	3.3	3.3	3.3
<b>Accreditation</b>				
Safety Standard	IEC	IEC	IEC	IEC
ROSH	ROSH COMPLIANT	ROSH COMPLIANT	ROSH COMPLIANT	ROSH COMPLIANT
ISO Certified Manufacturer	ISO 9001:2015	ISO 9001:2015	ISO 9001:2015	ISO 9001:2015
<b>Dimensions and Weight</b>				
Dimensions of Heater [mm]	W220 x H390 x D89	W220 x H390 x D89	W220 x H390 x D89	W220 x H390 x D89
Net Weight(Heater only) [kg]	1.3	1.6	1.3	1.6
Gross Weight(Heater+Shower Set only) [kg]	2.6	2.9	4.5	4.8

