

1m or more from the unit

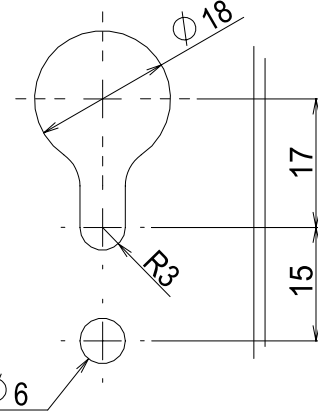
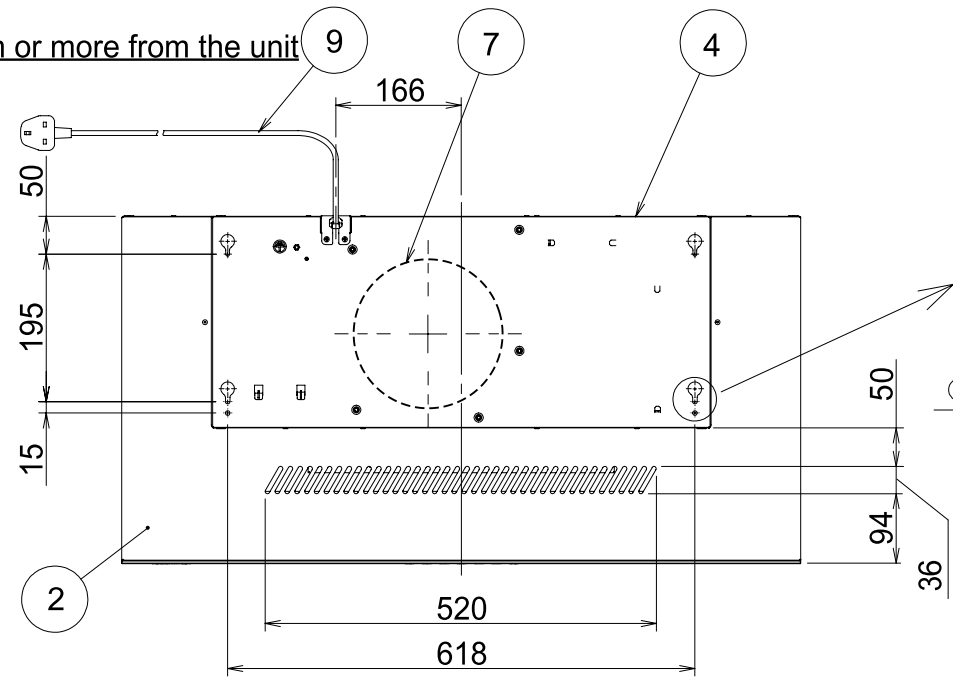

Detail: Installation hole

Accessories	
Flat washer	6pcs
ST5×40 Wood screw	6pcs
Plastic expansion pipe	6pcs
ST4.2×16 Flat head screw	4pcs

Major Parts				
No	Parts	Material	Finish	Color
1	Hood front plate	Toughened Glass		
2	Hood frame	Stainless steel	No,4	
3	Oil panel	Stainless steel	No,4	
4	Body	Galvanized steel		
5	Rectifier baffle panel	Stainless steel	No,4	
6	Filter	Galvanized steel(Aqua Slit Filter,1 layer)		
7	Fan motor	4 Pole capacitor motor,class F		
8	Switch	Static electrical switch(On/Off,Low,Med,Hi,Timer,Light)		
9	Power supply cord	Cabtire cable		
10	Lighting	LED(Daylight white color),1.5W × 2pc		
11	Oil tray	Polycarbonate		*Accessories

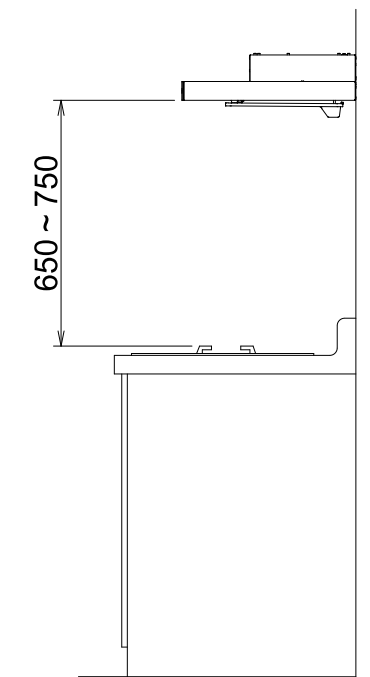
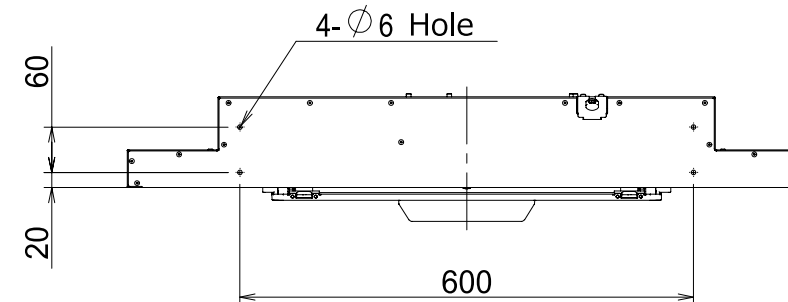
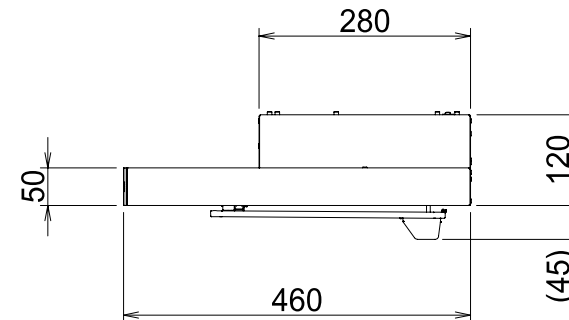
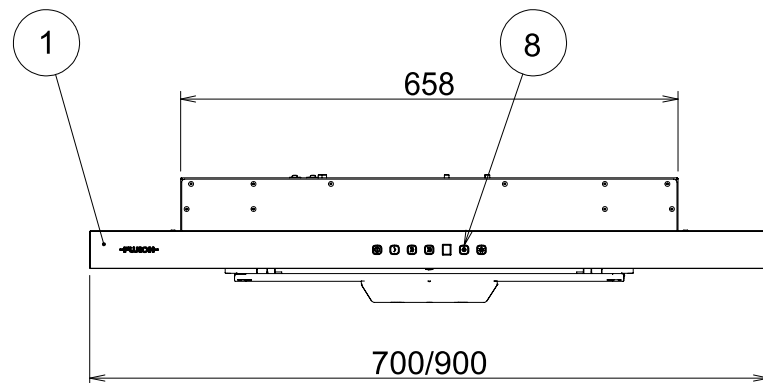

Standard Installation

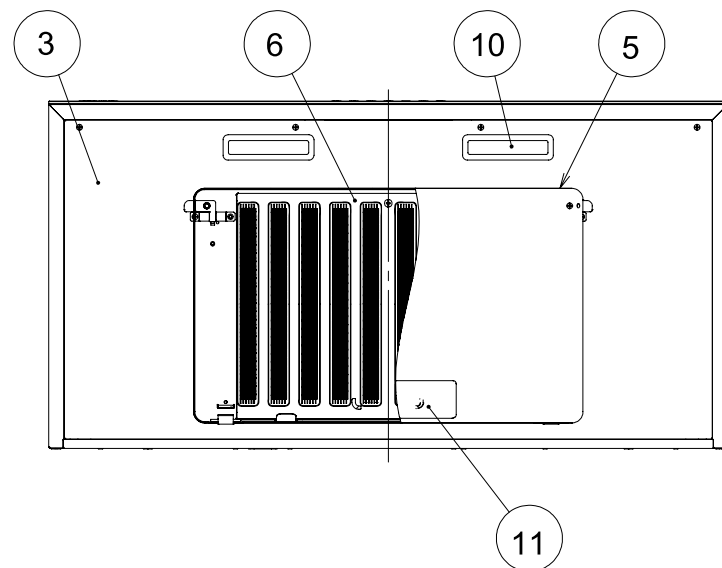

Specifications

Model	Voltage (V)	Speed	Frequency (Hz)	Power consumption (W)	Airflow(m³/h)		Sound (db)	Weight (kg)
					0Pa	-		
FR-MS1970R FR-MS1990R	220	Hi	50	141	245	-	53	9.9 10.6
		Med		105	175	-	44	
		Low		100	135	-	37	
	230	Hi		148	260	-	55	
		Med		124	185	-	45	
		Low		108	145	-	39	
	240	Hi		163	275	-	56	
		Med		134	195	-	47	
		Low		115	150	-	40	

Motor class	4 Pole capacitor motor	insulation resistance	Over 10MΩ (500Vmegger)	Withstanding voltage	AC1000V for 1min	Insulation class	F
-------------	------------------------	-----------------------	------------------------	----------------------	------------------	------------------	---

Airflow measured by JIS C9603 chamber method

FR-MS1990RGCM	Champagne metallic glass /Stainless steel		
FR-MS1990RGBK	Black glass /Stainless steel		
FR-MS1970RGCM	Champagne metallic glass /Stainless steel		
FR-MS1970RGBK	Black glass /Stainless steel		
Model	Product code	Color	Note

Created date	23/5/2019	Product category	Cooker Hood
Updated date	20/10/2022	Model	FR-MS1970/90R

-FUJIOH- Scale 1/10 Product outline drawing

Mark	Revised record	Date
△	Standard installation height drawing change	20/10/2022

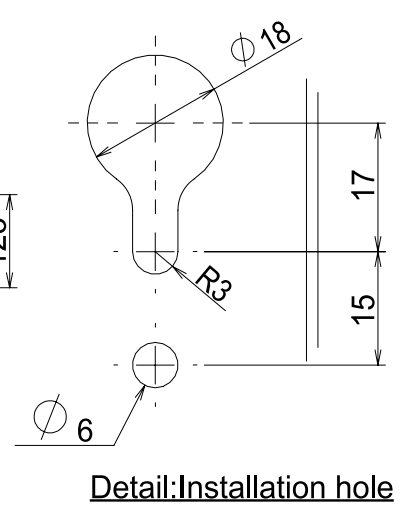
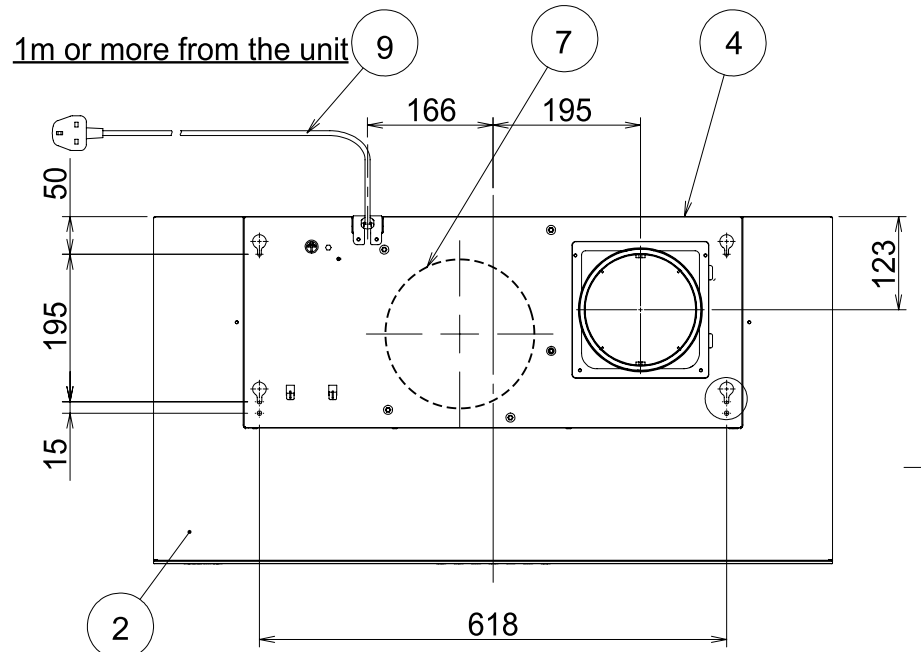

Accessories

Flat washer	6pcs
ST5×40 Wood screw	6pcs
Plastic expansion pipe	6pcs
ST4.2×16 Flat head screw	4pcs

Major Parts				
No	Parts	Material	Finish	Color
1	Hood front plate	Toughened Glass		
2	Hood frame	Stainless steel	No,4	
3	Oil panel	Stainless steel	No,4	
4	Body	Galvanized steel		
5	Rectifier baffle panel	Stainless steel	No,4	
6	Filter	Galvanized steel(Aqua Slit Filter,1 layer)		
7	Fan motor	4 Pole capacitor motor,class F		
8	Switch	Static electrical switch(On/Off,Low,Med,Hi,Timer,Light)		
9	Power supply cord	Cabtire cable		
10	Lighting	LED(Daylight white color),1.5W × 2pc		
11	Oil tray	Polycarbonate		*Accessories
12	Exhaust port	polypropylene		*Accessories

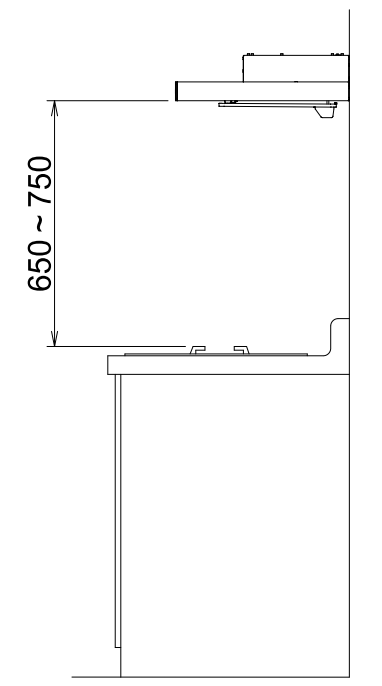
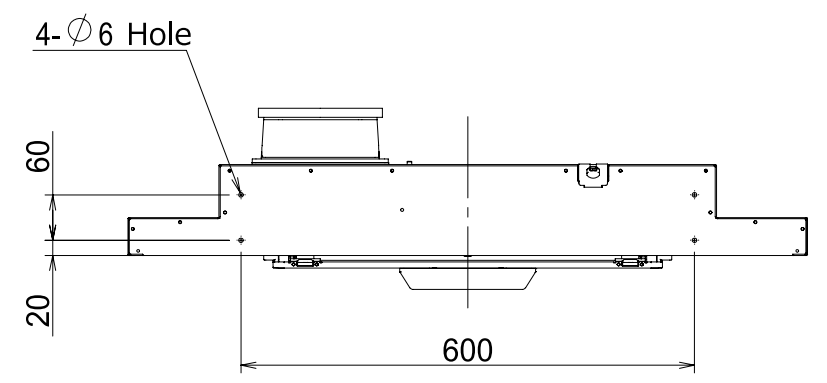
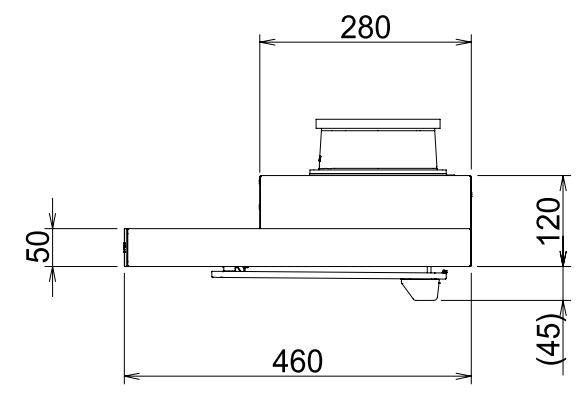
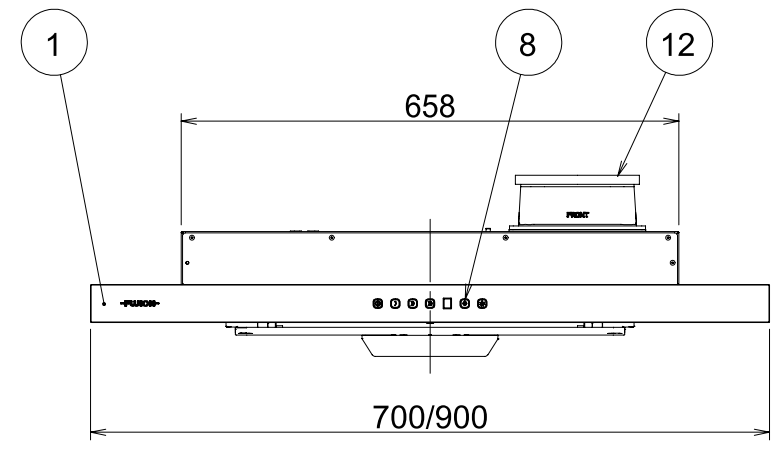

Standard Installation

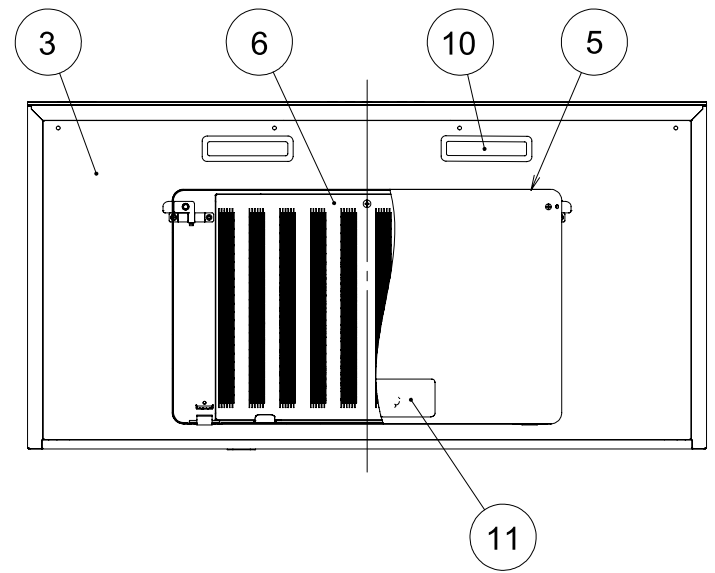

Specifications								
Model	Voltage (V)	Speed	Frequency (Hz)	Power consumption (W)	Airflow(m ³ /h)		Sound (db)	Weight (kg)
					0Pa	-		
FR-MS1970V FR-MS1990V	220	Hi	50	218	400	-	57	9.4 10.3
		Med		156	320	-	52	
		Low		120	230	-	45	
	230	Hi		233	420	-	58	
		Med		169	330	-	53	
		Low		130	250	-	46	
	240	Hi		255	435	-	59	
		Med		182	350	-	54	
		Low		140	260	-	47	

Model	Product code	Color	Note
FR-MS1990VGCM		Champagne metallic glass /Stainless steel	
FR-MS1990VGBK		Black glass /Stainless steel	
FR-MS1970VGCM		Champagne metallic glass /Stainless steel	
FR-MS1970VGBK		Black glass /Stainless steel	

Motor class	4 Pole capacitor motor	insulation resistance	Over 10MΩ (500Vmegger)	Withstanding voltage	AC1000V for1min	Insulation class	F
-------------	------------------------	-----------------------	------------------------	----------------------	-----------------	------------------	---

Airflow measured by JIS C9603 chamber method

Created date	23/5/2019	Product category	Cooker Hood
Updated date	20/10/2022	Model	FR-MS1970/90V
-FUJIOH-		Scale	1/10
Product outline drawing			

Mark	Revised record	Date
△	Standard installation height drawing change	20/10/2022