

-FUJIOH-

Built-in Gas Hob

Operating / Installation Manual

FH-GS6520 SVSS
FH-GS6530 SVSS
FH-GS6520 SVGL
FH-GS6528 SVGL
FH-GS6530 SVGL

Please read this manual carefully
before using this appliance.

Content

1.Important safety precautions and recommendations -----	1
2.Warning symbols for toughened glass of the gas hob -----	2
3.Models and parts of the gas hob -----	3
4.How to use the gas hob -----	4
5.Cleaning and maintenance -----	6
6.Installing the battery -----	9
7.Installation instructions -----	10
8.Inlet gas connection -----	13
9.Gas hob not functioning -----	14

Dear customer,

Thank you for selecting this Fujioh product.

The safety precautions and recommendations provided in the manual are for your own safety. Please keep this manual for future reference relating to the operation and maintenance of the gas hobs.

This gas hob shall be used for domestic cooking only. Any other usage is strictly prohibited. The manufacturer declines all responsibilities in the event of damages caused by improper, wrong or irrational usage of the gas hob. Read and understand the instructions before installation and operation of the gas hob.

1. Important safety precautions and recommendations

- a. Unpack the gas hob from the carton box and inspect for physical damage. In case of doubt, do not install / operate the gas hob and contact your supplier for professional advice.
- b. Never attempt to modify the gas hob.
- c. This gas hob shall be installed in a well-ventilated room and in compliance with the local regulations.
- d. After cooking, ensure that the gas control knobs are turned back in the off position.
- e. This gas hob can be used by children aged from 14 years old and above if they understand the operation of the gas hobs and are aware of the hazards caused due to improper usage.
- f. Do not touch the parts of the gas hob which are heated by the flame during operation of the gas hob. Note that these parts remain hot for a certain period after the gas hob is turned off.
- g. Never leave the gas hob unattended while cooking.
- h. Never try to extinguish a cooking fire with water.
- i. If the gas hob is used for a prolonged period, there may be necessary to provide more ventilation by opening more windows.
- j. In the event of the burner flame being accidentally extinguished, turn off the burner control knob and do not attempt to re-ignite the burner for at least one minute.**
- k. While using the hob for the first time, you may smell some odour like a burning smell or notice a small emission of smoke. This is normal and is not toxic. This smell will go off after few usages.

2. Warning symbols on the toughened glass of the gas hob



Do not place anything e.g. flame tamer or asbestos mat, between pan and pan support, as serious damage to the appliance may result in.

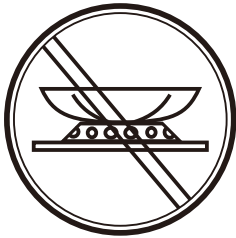

Do not remove the pan support and enclose the burner with a wok stand, as this will concentrate and deflect heat onto the glass top.

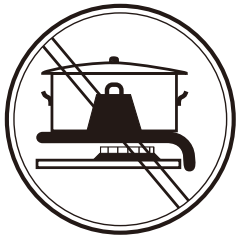

Do not use large pots or heavy weights that can bend the pan support or deflect flame onto the glass top.



Locate pan centrally over the burner so that it is stable and does not overhang the appliance.



Use only a wok support supplied or recommended by the manufacturer of the appliance.

3. Models and parts of the gas hob

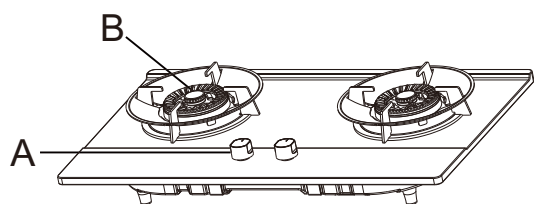

FH-GS6520 SVSS

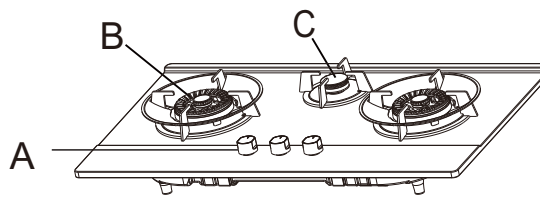

FH-GS6530 SVSS

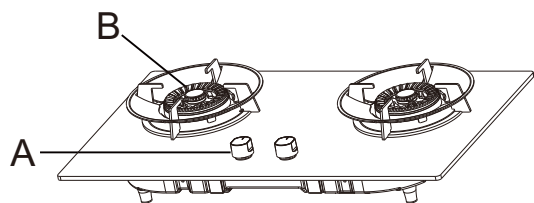

FH-GS6520 SVGL
FH-GS6528 SVGL

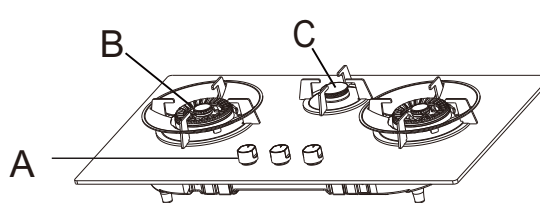

FH-GS6530 SVGL

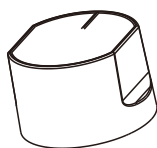

A. Burner control knob

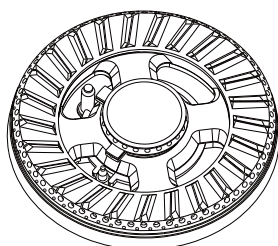

B Ultra-rapid

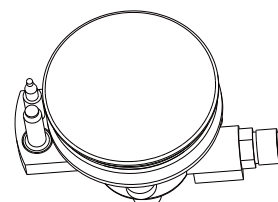

C Auxiliary

Table 1 – a) Nozzle (Injector) and burner characteristics for LPG / G30 gas at 30 mbar

Type of burners	Nominal heat input (kW)	Outer ring Ø injectors (mm)	inner ring Ø injectors (mm)
Ultra-rapid	5.0	0.98	0.48
Auxiliary	1.1	0.53	—

Table 1 – b) Nozzle (Injector) and burner characteristics for Town gas / G110 gas at 10 mbar

FH-GS6520 SVGL / FH-GS6528 SVGL / FH-GS6530 SVGL

Type of burners	Nominal heat input (kW)	Outer ring Ø injectors (mm)	inner ring Ø injectors (mm)
Ultra-rapid	3.8	2.40	1.10
Auxiliary	1.1	1.45	—

FH-GS6520 SVSS / FH-GS6530 SVSS

Type of burners	Nominal heat input (kW)	Outer ring Ø injectors (mm)	inner ring Ø injectors (mm)
Ultra-rapid	4.1	2.60	1.10
Auxiliary	1.1	1.45	—

4. How to use the gas hob

Gas burners

The gas flow to the burner can be regulated by turning the corresponding control knob to one of the following positions. (see Fig.1)

- OFF (close valve)
- 🔥🔥 High (maximum aperture or flow)
- 🔥 Low (minimum aperture or flow)

The size of flame depends on the position of the related burner control knob.

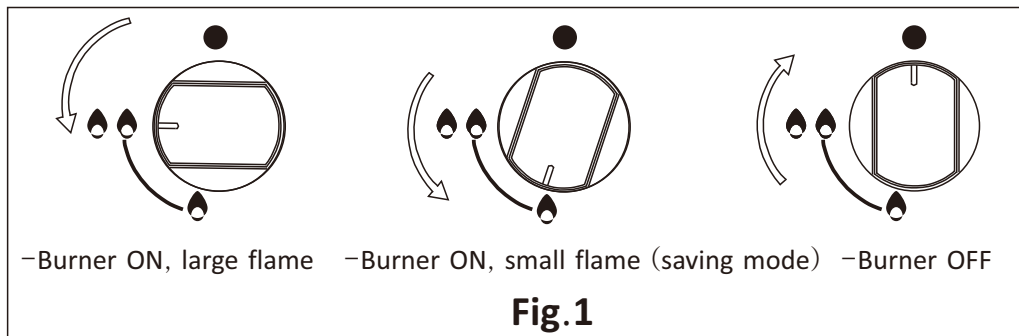

The burner should be set at large flame during the initial phase of the cooking to allow quick heating of the cooking contents. After quick heating, turn the control knob to small flame for slow warming of food or maintaining heating conditions. Other flame adjustment can be achieved by positioning the indicator between the large flame and small flame. Never adjust the flame size between the large flame and OFF position.

Igniting the burners

The appliance is equipped with automatic ignition system and flame failure safety device. To ignite the burner, carry out the following steps:

- a. Press and turn the corresponding control knob anti-clockwise to the large flame position. The gas burner will be ignited.
- b. At this position, hold down the control knob for 5 seconds to allow the flame to heat up the thermocouple.
- c. Then, release the knob and the flame shall be remained lighted up.
- d. Turn the control knob to achieve the flame as desired.
- e. If the flame can't be lighted, turn the control knob clockwise to the off position. Then repeat step a to c.
- f. After cooking is completed, turn the control knob clockwise to the off position.

Battery Ignition

The automatic ignition system is powered by a 1.5 V battery. If the automatic ignition does not work, check the battery compartment under the gas hob to ensure that the battery is positioned correctly. Replace the battery if necessary (see Fig.9 in page 9).

Selection of burners and diameters of pan

On the control panel, near every knob, there is a diagram to indicate the burner controlled by the corresponding knob. Select the burner in accordance to the diameter of the pan used and the heat input.

The recommended burners for the flat bottom pan diameters are as follow:

Types of burners	Pan diameter (cm)
Auxiliary	8 to 14
Ultra-rapid	20 to 26

It is important that the diameter of the pan is suitable to the heat input of the burner. During usage, adjustment of the control knob is required to ensure that the flame does not extend out from the bottom of the pan. (see Fig.2)

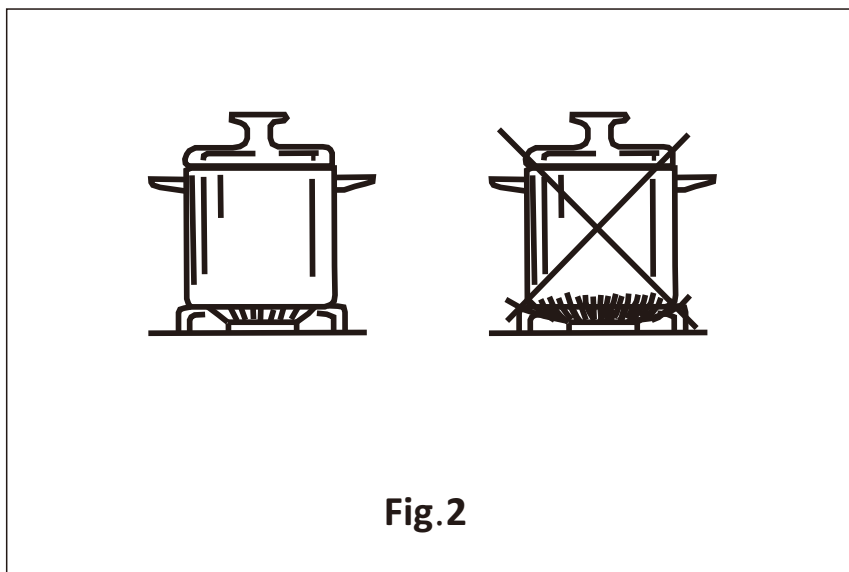

Correct use of Ultra-rapid burner

To use the wok, you need to position the wok directly onto the center of the pan support. Recommended wok top's open diameter shall not exceed 36 cm. For gas hob models without Auxiliary, while using the flat bottomed pan with diameter less than 12 cm, you need to position the mini trivet (Fig.3) provided onto the pan support. After lighting the burner, adjust the control knob so that the flame length do not extend out from the bottom of the pan so as to prevent overheating of the pan handle (see Fig.2 in page 5).

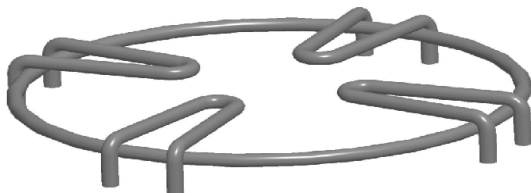
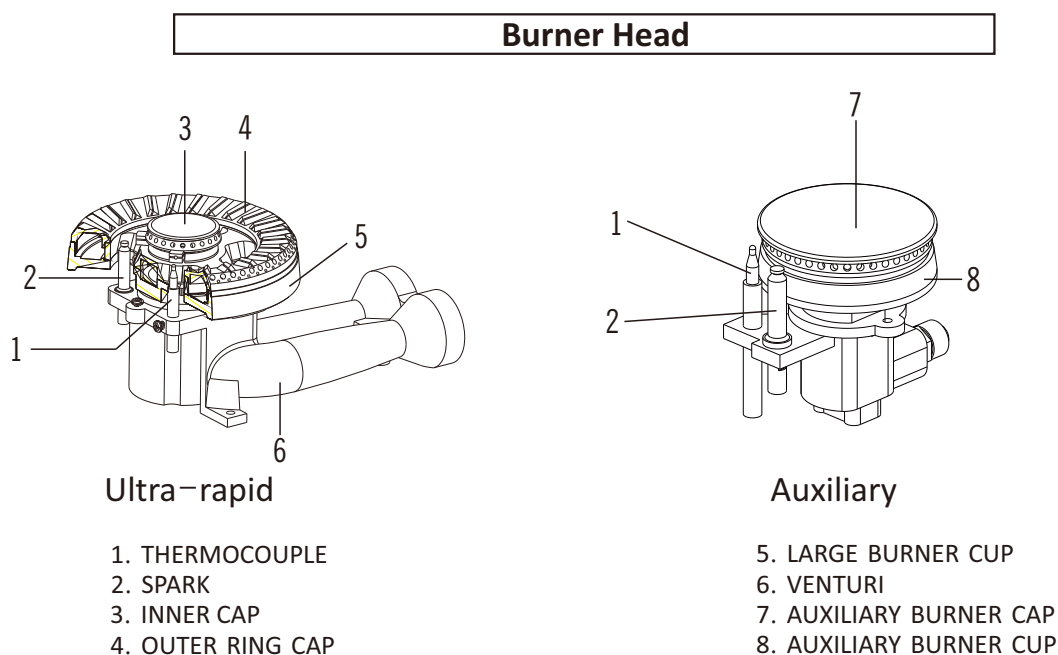

Fig.3

Flame failure safety device

This gas hob is equipped with flame failure safety device. In the event, the flame is accidentally extinguished, the supply of gas to that burner will be shut off. Before re-lighting the burner, turn off the burner control knob and do not attempt to re-ignite the burner for at least one minute.



Note: The coating of the burner caps and burner cups might decolorize or peel off after the appliance is used. However this will not affect the performance of the appliance.

5. Cleaning and maintenance

Cleaning and maintenance should be carried out only after the appliance has turned cold, especially when cleaning burner and the cast iron support. Avoid leaving alkaline or acid substances (lemon juice, vinegar etc.) on the hob surface. Avoid using acid or chlorine-based cleaning products.

Caution:

Special care should be taken to the lower surface of the appliance as this area is not designed or intended to be touched. It also may contain sharp or rough edges, that may cause injury. For safety, always wear a pair of rubber gloves while cleaning.

To extend the life of the cooktop, please make sure that the appliance are cleaned carefully and thoroughly on a frequent basis, keeping following in mind:

- **SURFACE OF ENAMEL PARTS**

All of the Enamel parts must be washed only with a sponge and soapy water or with non-abrasive products.

- **STAINLESS STEEL SURFACES**

Stainless steel can be stained if it remains in contact with highly calcareous water or aggressive detergent (containing phosphorous) for an extended period of time. Stainless steel parts must be rinsed with water and dried with a soft and clean cloth, it is also recommended to clean up any spills as soon as possible.

- **PAINTED PARTS AND SILKSCREEN PRINTED SURFACES**

Clean using an appropriate product. Always dry thoroughly. These parts must be cleaned very carefully to avoid scratching and abrasion.

- **BURNERS AND PAN SUPPORT**

These parts can be removed and cleaned with appropriate products.

Cleaning the Wok Burner

The burner cup must always be kept clean. While cleaning the burners, remove the burner caps and use a cotton bud, toothbrush or some other items to clean out any incrustations or dirt from area marked as “H” in Fig.4. This procedure is necessary to ensure correct the functioning of the burner. Clean the burner caps using needle or toothbrush to remove the dirt and carbon, blocking the burner holes. (Fig.5)

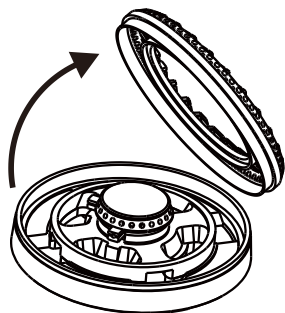

Fig.4

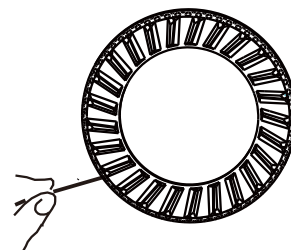
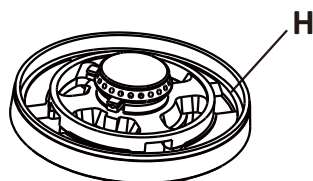

Fig.5

After cleaning the burners and the caps they must be well dried and put back correctly. It is very important to check that the burner cups F, burner cap A and cap B has been correctly positioned (Fig.6)–failure to do so can cause serious problem.

As shown by the arrow, the "M" positioning of the inner cap cover must be aligned with the "m" clamping position of the burner cup, and the "N" positioning of the inner cap cover must be aligned with the "n" clamping position of the burner cup (as shown on the left side of Fig.6). The burner correctly positioned must rotate.

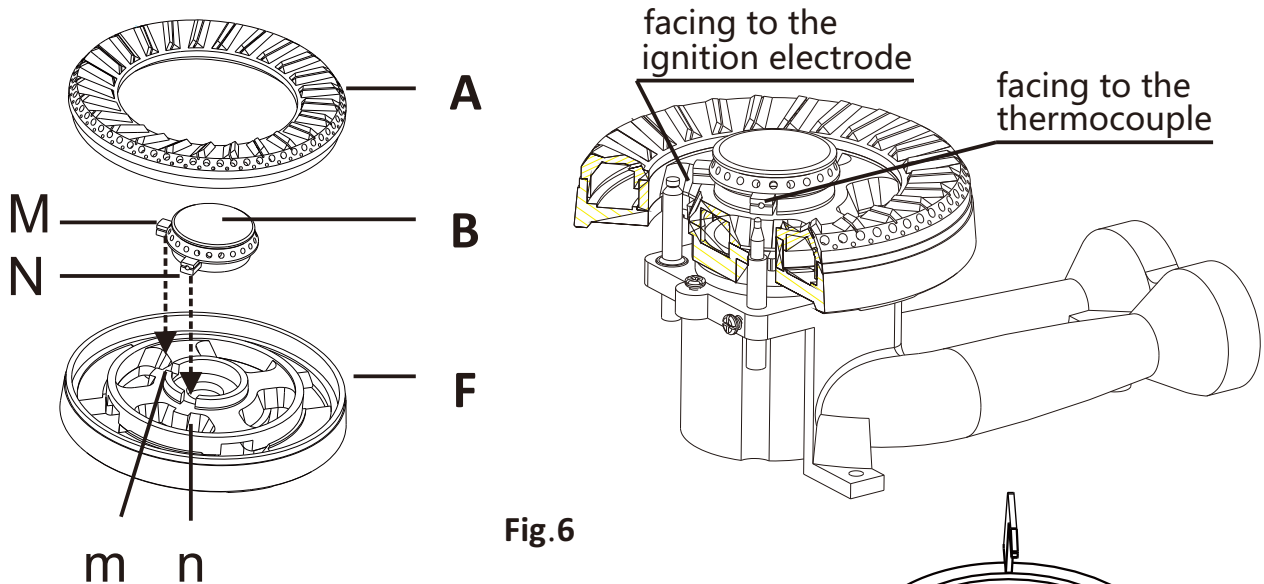

Fig.6

How to place the pan support

In order to prevent the pan support from rotating, there is a special positioning support. During installation, make sure that the special positioning support is placed exactly on the groove of the spill tray (Fig. 7).

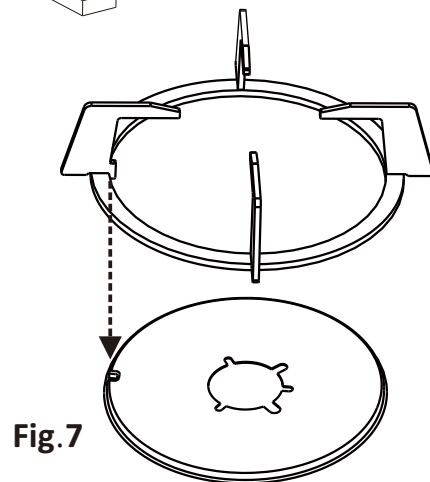

Fig.7

Check that the ignition electrode "S" (Fig.8) is always clean to ensure trouble-free sparking. Check that the probe or thermocouple "T" (Fig.8) is always clean to ensure correct operation of the safety valves. Both the ignition electrode and the thermocouple must be very carefully cleaned.

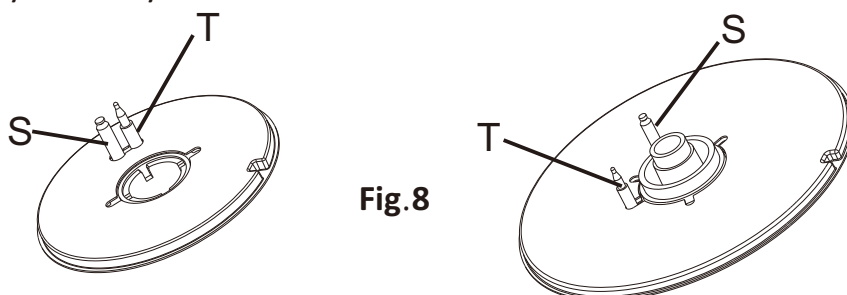

Fig.8

Note: Regular use may cause discoloring around the burners due to high temperature of the flame.

General advice

- ✓ When the appliance is not being used, it is advised to keep the gas regulator or TG supply level closed.
- ✓ The gas hob requires regular maintenance by qualified technician for its reliable operation. We recommend the gas hob maintenance to be carried out at least once in every 18 months.

6. Installing the battery

Insert a DC1.5V battery into the battery compartment (see below Fig.9) in the cover. This battery is the power supply for the electronic ignition of gas burners.

Notes for battery installation or replacement:

- Only use a DC1.5V battery (size “D”).
- Check for correct polarity (label to the side of the battery compartment).
- Do not use Alkaline battery.

Important notes:

- Remove the battery if the hob is not going to be used for a long time.
- If the battery becomes weak or leaks, replace it immediately.
- Avoid touching the leaked liquid and make sure it does not come into contact with clothes or other items.
- Clean the battery compartment carefully before installing the new one.
- The battery is a potential source of danger for children. Keep them away.
- Dispose the batteries properly.

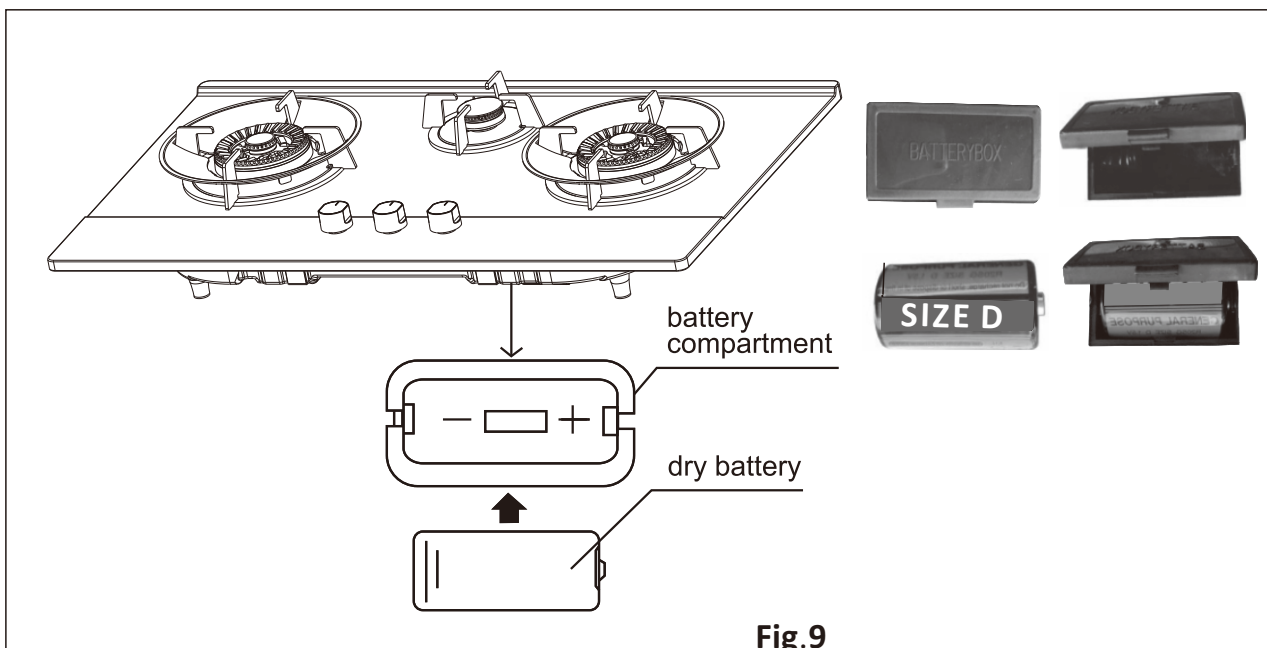

Fig.9

7. Installation instructions

Important

- The appliance should be installed, regulated and adapted to function with other types of gas by a qualified installation technician. Failure to comply with this condition will retain the guarantee validation.
- **The appliance must be installed in compliance with regulations in force in your country and in observation of the manufacturer's instructions.**
- **Some appliances are supplied with a protective film on steel and aluminum parts. This film must be removed before using the cooker.**
- **The appliances must be installed in heat resistant units.**
- **The walls of the units should not be higher than work top and must be capable of resisting temperatures of 75°C and above.**
- **Do not install the appliance near inflammable materials (eg.curtain).**
- **Incorrect installation, for which the manufacturer or distributor accepts no responsibility, may cause personal injury or damage.**

Technical information

The appliance is designed to be embedded into kitchen fixtures measuring 600 mm in depth.

In order to install appliance into the kitchen fixture, a hole with the dimensions shown at the cutting size board (Fig.11 in page 11) has to be made, taking following into consideration:

- The distance, between the bottom of the cooktop and the upper surface of any other appliance or internal shelf must be at least 10-15 cm (Fig.13 in page 12).
- The cooker top must be kept no less than 200 mm away from any side wall.
- The hob must be installed at least 70mm away from the rear wall(Fig.10 in page 11).
- There must be a distance of at least 750 mm between the hob and any wall of the cupboard for extractor hood positioned immediately above (Fig.10 in page 11).
- It is essential to install a heat baffle between the bottom of the hob and the underlying unit.

No conversion to different gases of another family is recommended, this appliance shall use the gas of the family that it is designed for and adjusted at factory.

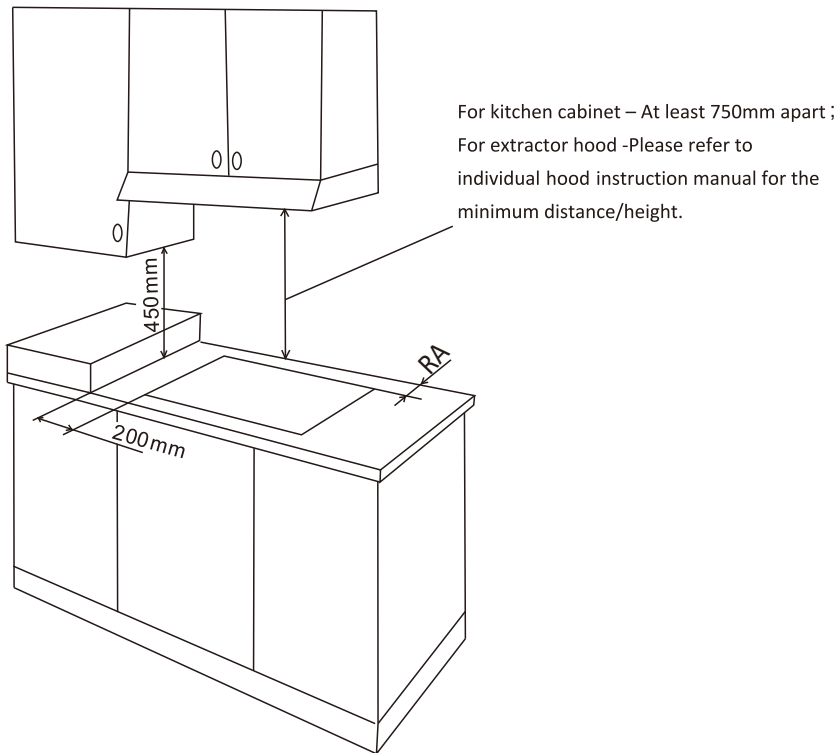
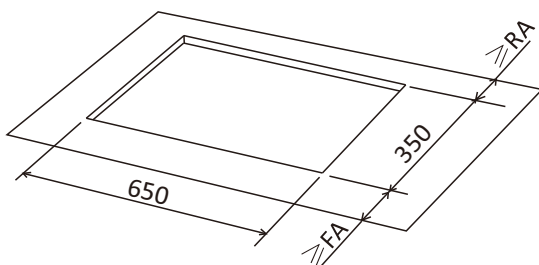

Fig.10

Cut-out dimension & replacement size

Please be ensure to use the correct dimensions as shown below for installation.

Model	Cut Out Dimension(mm)		Replacement size(mm)	Height(mm)
FH-GS6520 SVGL	W650xD350	FA66xRA70	W(650-730)xD(350-410) × R120	85
FH-GS6520 SVSS				
FH-GS6530 SVGL	W705xD405	FA71xRA85	W(690-830)xD(390-470) × R120	85
FH-GS6528 SVGL				
FH-GS6530 SVSS				



FH-GS6520 SVSS
FH-GS6520 SVGL

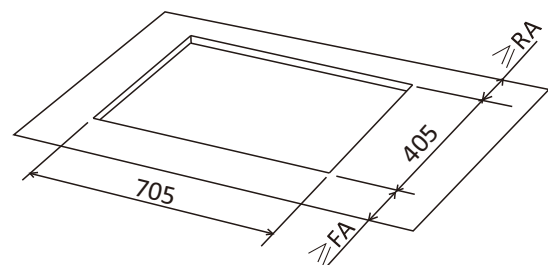

FH-GS6530 SVSS
FH-GS6528 SVGL
FH-GS6530 SVGL

Fig.11

Installation of gas hob in kitchen cabinet with door

The cabinet has to be made in accordance to the specific requirements to ensure proper operation of the gas burners. When the flame is turned down to minimum, pressure changes due to opening and closing of the cabinet doors. The cabinet should have openings to facilitate ventilation (see Fig.12 & 13).

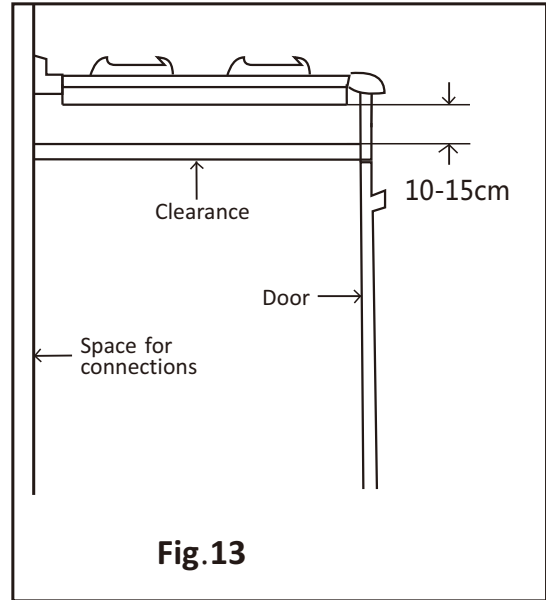
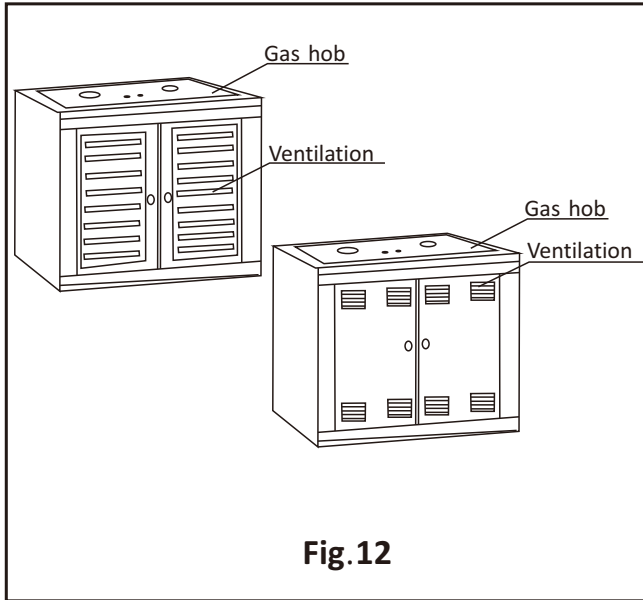

Installation of built-in oven under the gas hob

If there is a built-in oven set to be installed under gas hobs, it is required that a horizontal partition with high temperature resistant material is built in between the gas hob and built-in oven. The distance between the surface of this partition to the under surface of the gas hob must be at least 10-15cm to allow air circulation and protect the rubber gas tubing from the heat of the built-in oven (see Fig.14).

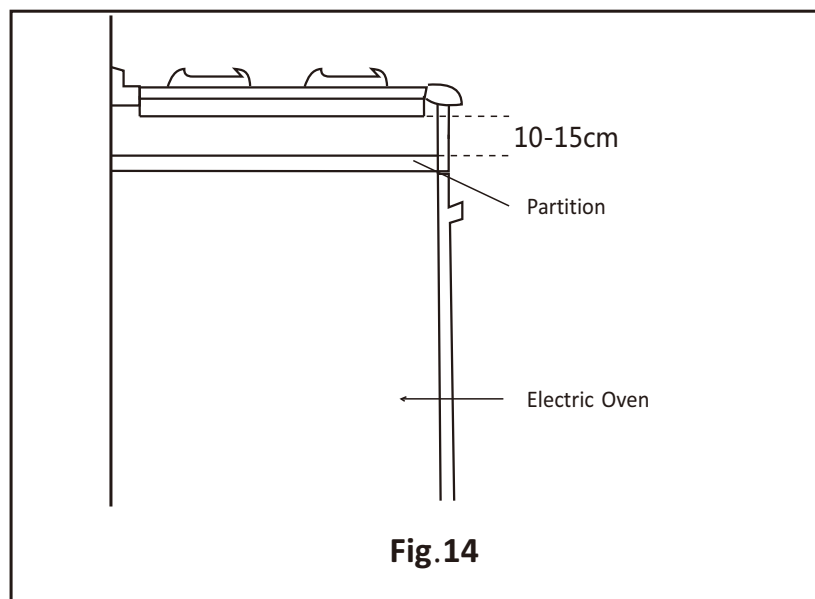

Ventilation requirement

The appliance must be installed in compliance with applicable local regulations concerning ventilation and the evacuation of exhaust gases.

Intensive and prolonged use may need additional ventilation, for example, opening of a window or to have a more efficient ventilation.

Choosing suitable surroundings

The room where the gas appliance is to be installed must have a natural flow of air so that the gas can burn. The flow of air must come directly from one or more openings made in the out-side walls with a free area of at least 100cm².

The openings should be closer to the floor and preferably far away from the product. The openings should also made sure that they are not blocked from inside or outside of the unit.

When these openings cannot be made, the necessary air can come from an adjacent room which is ventilated as required, as long as it is not a bedroom or a dangerous area. In this case the kitchen door must allow the passage of the air.

8. Inlet gas connection

Important:

- The appliance should be installed, regulated and adapted to function with other types of gas by a qualified installation technician.
- The appliance is fitted with specified gas type as shown in the specification nameplate and cannot be used or converted to any other type of gas.

Installation

The appliance is predisposed and adjusted to operate with the gas indicated on the specifications nameplate located at the bottom of the appliance.

Please ensure that the intended gas type used corresponds with that specified on the nameplate.

Gas connection to the gas hob

The appliance should be connected to the gas-supply by licensed installer. During installation of this appliance, it is essential to fit an approved gas tap to isolate the supply from the appliance for the convenience of any subsequent removal or servicing. Connection of the appliance to the gas mains or liquid gas must be carried out according to the prescribed regulation in force, and only after it is ascertained that it is adaptable to the type of gas to be used. In the case of connection to liquid gas, by tank, use pressure regulators that conforms the regulation in force. Connection to the gas course must be done in such a way that there are no any stress points at any part of the appliance.

Important:

For safety, and correct regulation of gas usages and long life of the appliance, ensure that the gas pressure conforms to the indications given in table 1 'Nozzle and burner characteristics'.

For LPG

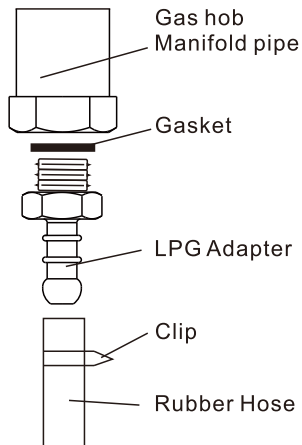

For Town Gas & Natural Gas

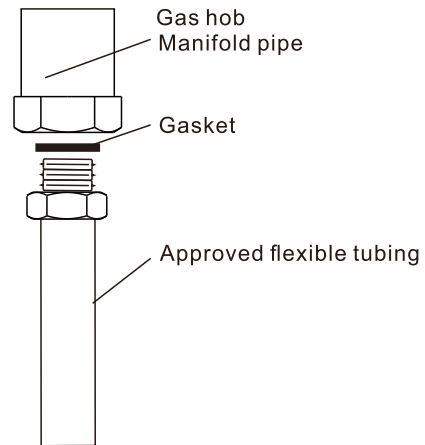

Gas leak test operation

After the gas pipe connection has been completed, the gas leak test must be performed before the installation is considered completed.

After connecting to the mains, check that all the couplings are correctly sealed, using soap solution.

NEVER use a naked flame. If bubbles appear, please close the gas valve immediately and re-adjust the gas connection before re-testing the appliance. Turn on the gas and ignite each burner. Check if the flame is blue without any yellow tipping. If there is abnormal flame, turn off the flame and check that the burner cap is properly positioned and the correct gas type is used.

9. Gas hob not functioning

In the event of any abnormal situations or malfunctions of the gas hob, do not attempt to rectify the situations or repair the gas hob. Contact the customer service center as mentioned in the warranty card for assistance. When contacting customer service center, please provide the model number.

Global Website
www.fujioh.com

FUJIOH INTERNATIONAL TRADING PTE.LTD.

Southeast Asia Regional Headquarters

3014A Ubi Road 1 #06-04 SINGAPORE 408703

Tel: +(65) 6286 3286 Fax: +(65) 6285 3285

E-mail: fit@fujioh.com.sg

Rev2 2022

全球网站
www.fujioh.com

FUJIOH INTERNATIONAL TRADING PTE.LTD.

东南亚区域总部

3014A Ubi Road 1 #06-04 SINGAPORE 408703

Tel: +(65) 6286 3286 Fax: +(65) 6285 3285

E-mail:fit@fujioh.com.sg

版次：2022年第二版

液化石油气

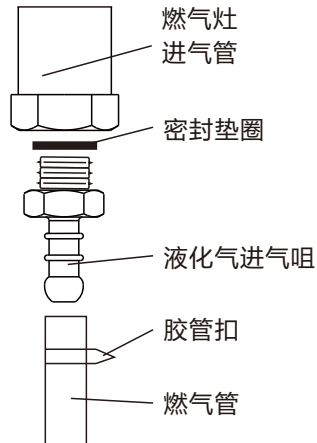

人工煤气/天然气

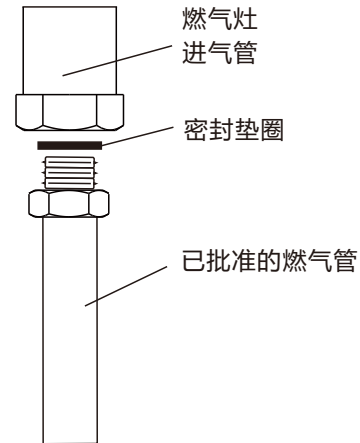

测试作业

燃气管连接完毕后，气体泄漏测试“必须”在安装完成之前进行。

连接到燃气总管后，使用肥皂液检查所有的接头是否正确密封。

禁止使用明火。如果出现气泡，在重新测试设备前，请立即关闭燃气阀，重新调整管路连接。

打开燃气，点燃每个燃烧器，检查火焰是否为蓝色，没有任何黄火。如果出现异常的火焰，关闭火焰。检查燃烧器火盖位置是否正确，以及使用的气源是否正确。

9、燃气灶故障处理

如果燃气灶出现异常或故障，不要试图自己去修理燃气灶。如需帮助，请联系保修卡中的客户服务中心。联系客服中心时，请提供具体型号。

空气流通要求

设备的安装必须符合当地有关通风和排气的相关规定，长时间密集的使用可能需要额外的通风，例如打开窗户，提高通风效率。

选择合适的环境

安装燃气灶的房间必须保持空气的自然流动，方便燃气的燃烧。必须直接通过一个或多个在外墙/侧壁上开的开口使空气流动，开口的有效面积至少为100平方厘米。

通风开口应靠近地板，最好远离产品设置的地方，而且必须保证既不能从外部堵塞，也不能从内部堵塞。

当无法打开这些开口时，空气可以从相邻的房间流通进入，只要该房间不是卧室或危险区域，就能够按照要求通风对调位置，这种情况下，厨房门必须敞开保持空气流通。

8、进气连接

重要提示：

- 燃气灶应由有资质的安装技术人员进行安装、调试，才可以使用。
- 燃气灶应使用铭牌所示的指定的气源，不能使用或转换为任何其它类型的气体。

安装：

燃气灶已经预先调整，请使用位于设备底部铭牌所指定的气源。

请确保即将使用的气源与铭牌上指定的气源相符。

燃气灶连接：

燃气灶应由获得许可的安装人员连接到燃气供应系统。在安装设备时，必须安装一个经过批准的燃气阀门，将供应气源与该燃气灶隔离，以方便后续拆卸或维修。必须按照现行的监管规例，将设备连接至燃气总管或液化气瓶，且只有在确定燃气灶适合于所使用的气源，才可使用。如果使用瓶装液化气，则必须使用符合现行法规的压力调节器。燃气管道的连接必须保证顺畅，不受任何外力作用。

重要提示：

为了安全起见，正确调节燃气和延长燃气灶的使用寿命，请确保燃气压力符合表1“喷嘴和燃烧器特征”中的指示。

在带门的厨柜内安装燃气灶

必须按照具体要求制作厨柜，当压力随柜门开关变化时，以确保当火焰调至最小时能正常工作。柜子应设有开口，以方便通风（见图12和13）。

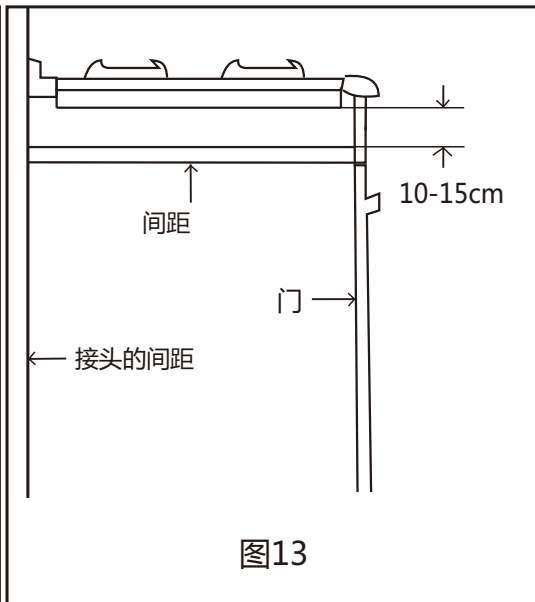
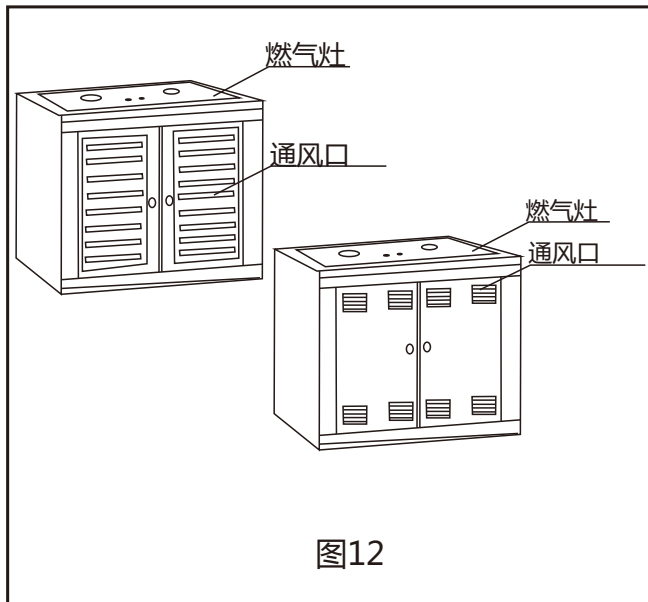

在燃气灶下安装内嵌式烤箱

如果在燃气灶下安装内嵌式烤箱，需要在燃气灶和内嵌式烤箱之间安装一片耐高温材料的水平隔板。水平隔板的上表面到燃气灶底部必须有至少10到15厘米的距离，确保空气流通，保护橡胶气体管免受内嵌式烤箱的加热（图14）。

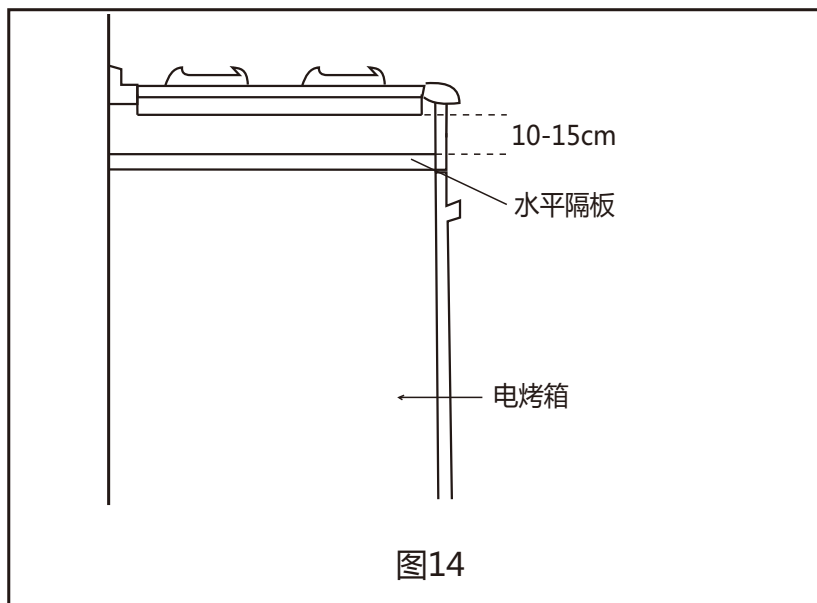

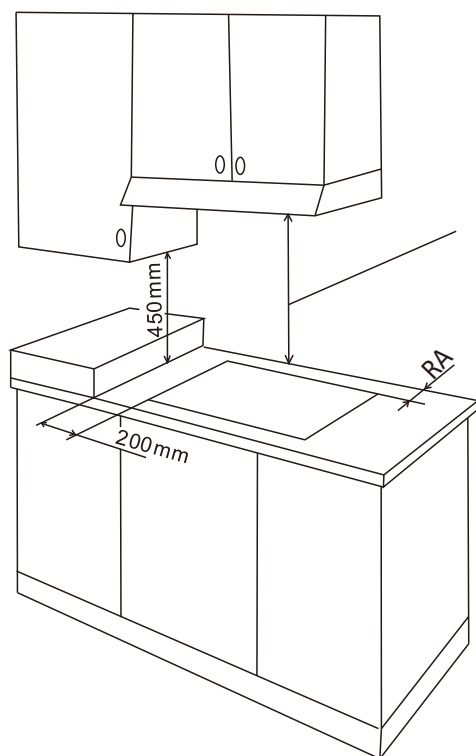

对于餐具柜——至少间隔750毫米；对于抽油烟机——有关最小距离/高度，请参阅抽油烟机说明书。

图10

开孔尺寸和更换大小

请确保使用正确的尺寸如下所示进行安装。

型号	安装尺寸(mm)		更换大小(mm)	高度(mm)
FH-GS6520 SVGL	W650xD350	FA66xRA70	W(650-730)xD(350-410) × R120	85
FH-GS6520 SVSS				
FH-GS6530 SVGL	W705xD405	FA71xRA85	W(690-830)xD(390-470) × R120	85
FH-GS6528 SVGL				
FH-GS6530 SVSS				

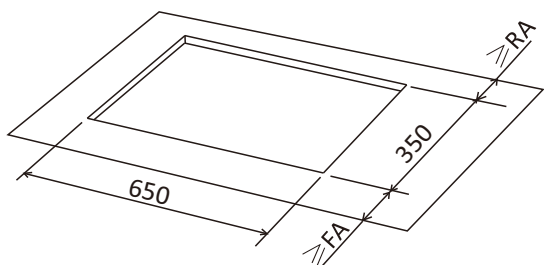

FH-GS6520 SVSS
FH-GS6520 SVGL

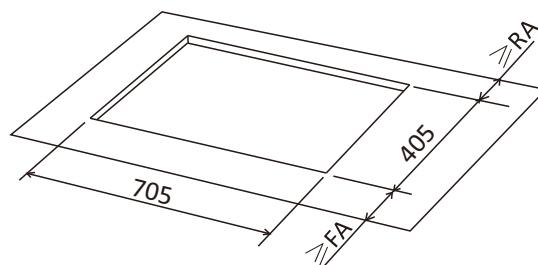

FH-GS6530 SVSS
FH-GS6528 SVGL
FH-GS6530 SVGL

图11

7. 安装说明

重要提示：

- 应由有资质的安装技术人员安装、调节燃气灶，并接通对应燃气。未能遵守安装条件的会造成无法正常保修。
- 该燃气灶的安装必须符合该国现行的法规，并遵守制造商的说明。
- 一些不锈钢面板灶具上会贴保护膜，在使用之前，必须先去除保护膜。
- 燃气灶必须装在耐热环境中。
- 燃气灶的墙壁不得高于工作台面，并能承受75°C以上的温度。
- 不要将燃气灶安装在易燃物品（例如窗帘）附近。
- 制造商或分销商对错误的安装不承担责任。而错误的安装可能造成人身伤害或损害。

技术信息：

燃气灶嵌入到600毫米深的厨房固定柜。

为了将燃气灶安装到厨柜中，必须开一个孔(图11)。此时，需要注意以下几点：

- √ 在厨柜内，灶台底部与其他装置或内部隔板的上表面之间，必须有至少10-15厘米的间隙（图13）。
- √ 灶具面板边必须与侧壁保持不小于200毫米的距离。
- √ 燃气灶安装到离墙壁不小于70毫米的位置（图10）。
- √ 燃气灶与壁柜或抽油烟机之间必须有至少750毫米的距离。
- √ 有必要在燃气灶的底部和其他装置之间安装隔热挡板。

不建议使用其它气源，燃气灶在出厂时就已经对相应的气源进行了调节。

注意：由于火焰温度过高，长期使用可导致燃烧器周围变色。

一般建议

- √ 当不使用时，建议关闭气体阀门并关闭燃气总阀门。
- √ 需要有资质的技术人员定期维护燃气灶，以保证其正常工作。建议燃气灶至少每18个月维护保养一次。

6. 电池安装

将一节直流1.5V电池插入电池盒中（见下图9）。该电池是燃气灶电子点火的电源。

电池安装或更换注意事项：

- 仅使用直流1.5伏电池（尺寸“D”）。
- 检查正负极是否正确（标签贴在电池盒的侧面）。
- 请勿使用碱性电池。

注意事项：

- 如果灶具长时间不使用，请取出电池。
- 如果电池电量不足或漏电，应立即更换。
- 避免接触泄漏的液体，并确保它不会接触衣服或其他物品。
- 安装新电池之前，请仔细清洁电池盒。
- 电池对儿童有潜在危险，不要让儿童触碰电池。
- 请妥善处理用完的电池。

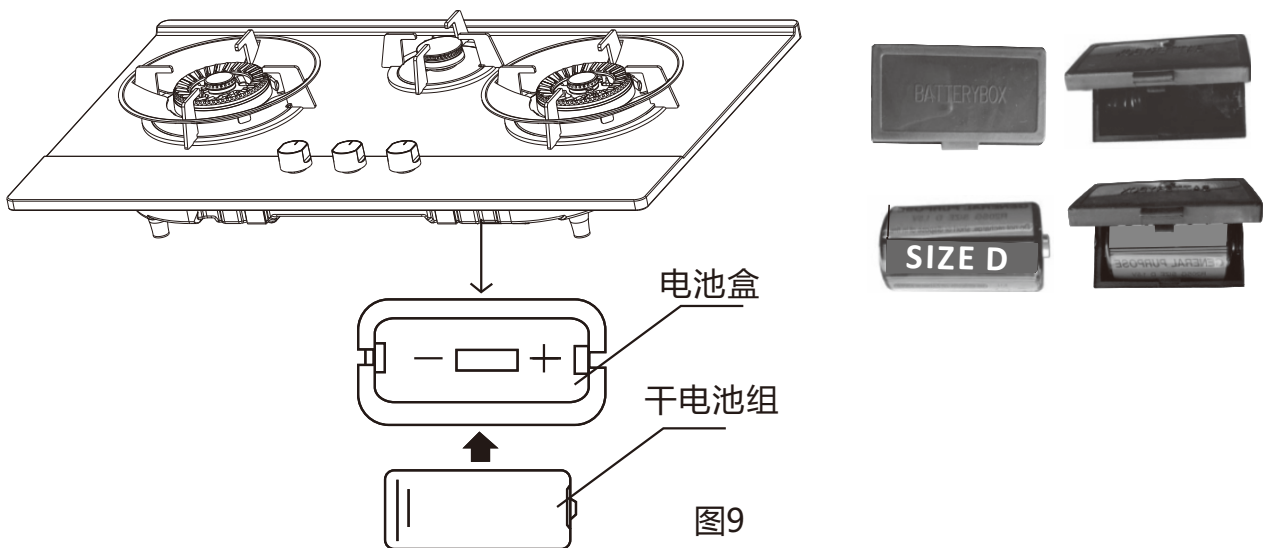

清洗后，燃烧器和火盖充分干燥，并放回原位。检查燃烧器F、火盖A和火盖B的位置是否正确（图6），否则可能会导致严重的问题。

如箭头所示，必须将内环火盖B的“M”定位与燃烧器座F位置的“m”卡位对准，内环火盖B的“N”定位与燃烧器座F位置的“n”卡位对准(如图6左侧)。位置正确内环火盖将不会旋转。图6右侧为正确放置后燃烧器的位置图。



图6

锅支架安放

为了防止锅支架转动，特设有定位支架，安装时请务必将定位支架与盛液盘的沟槽正对（图7）。位置正确锅支架不会旋转。

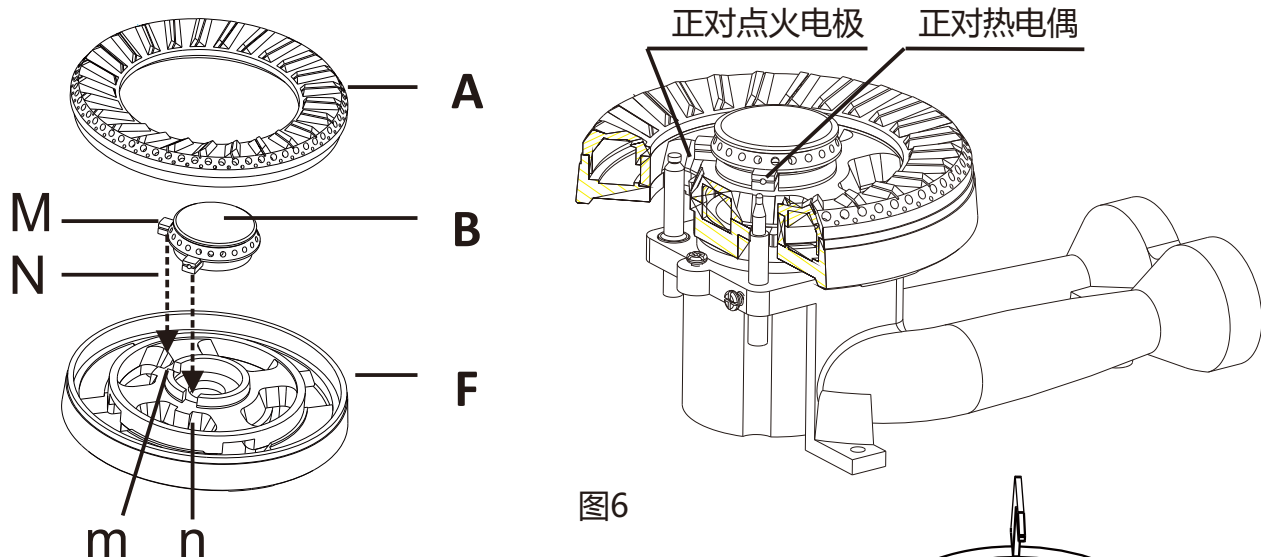

图7

检查点火电极“S”（图8）是否保持干净，以确保点火是正常的。检查探头或热电偶“T”（图8）是否干净，以确保熄火保护装置正常工作。必须非常仔细地清洗点火电极和热电偶。

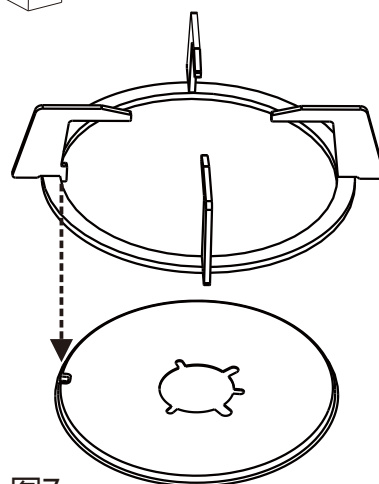

图8

注意事项：

需要特别注意燃气灶的底部，因为该区域不能触摸的，其设计可能包含锋利或粗糙的边缘。为安全起见，清洁时务必戴一副橡胶手套。

为了延长炉灶面的使用寿命，有必要经常对设备进行仔细彻底的清洁。
请牢记以下说明：

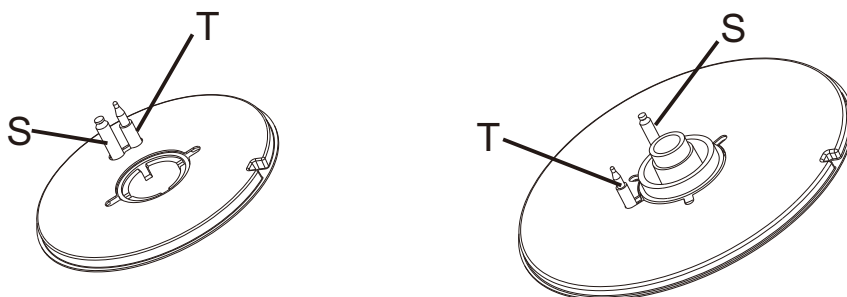
•铸铁件

所有铸铁部件必须用海绵和肥皂水或非腐蚀性清洗液。

•不锈钢表面

如果长时间与高钙质水或腐蚀性洗涤剂(含磷)接触，会使不锈钢生锈。必须用水清洗不锈钢部件，然后用柔软干净的布擦干，同时需要尽快清理溢出物。

•喷涂零件和丝印品表面

喷漆零件和丝印品表面 使用适当的清洗液进行清洁。产品必须时刻保持彻底干燥。这些部件必须非常小心地清洗，以避免刮伤和磨损。

•燃烧器和支架

这些部件可以进行产品拆卸和清洗。

清洗燃烧器

燃烧器顶部必须保持清洁。燃烧器清洗时，取下燃烧器火盖，用棉签、牙刷或其他物品清除图4中“H”区域的水垢或污垢。为确保燃烧器的功能正确，这一程序是必要的，使用针或牙刷清洁燃烧器火孔，清除堵塞燃烧器火孔的污垢和积碳（图5）。



图4



图5

主燃烧器的正确使用

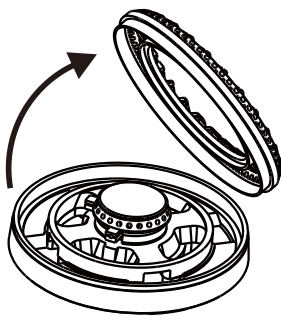
使用炒锅时，你需要把锅直接放在支架的中心。建议炒锅顶端开口直径不超过36厘米。使用没有辅助燃烧器的燃气灶时，如果平底锅的直径小于12厘米，需要将提供的小平架放置在锅支架上。点燃燃烧器后，调整控制旋钮，使火焰长度不从锅底探出来，以防止锅柄过热（见图3）。

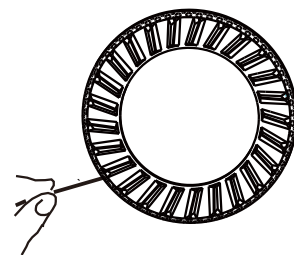
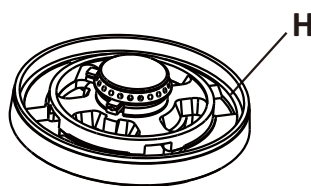
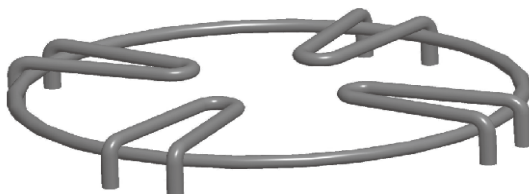

小平架

图3

熄火保护装置

本燃气灶设有熄火保护装置。在火焰意外熄灭的情况下，燃烧器的气体供应将自动关闭。在重新点燃燃烧器之前，关闭燃烧器控制旋钮，并且至少在一分钟内不要重新点燃燃烧器。

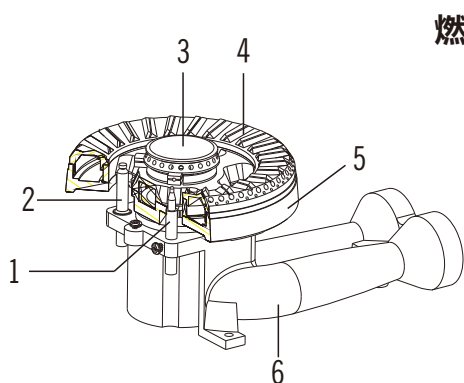

主燃烧器

- 1. 热电偶
- 2. 点火针
- 3. 内环火盖
- 4. 外环火盖

燃烧器结构

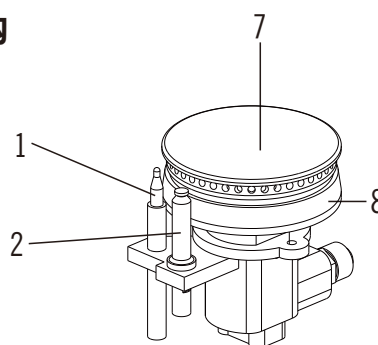

辅助燃烧器

- 5. 主燃烧器火盖座
- 6. 炉头
- 7. 辅助火盖
- 8. 辅助火盖座

备注：燃气灶使用中，火盖涂层可能产生脱色或剥落，但这不会影响燃气灶的性能。

5. 清洁和维护

清洗和维护应在燃气灶冷却后进行，特别是清洗燃烧器和铸铁支架时，避免在表面留下碱性或酸性物质(柠檬汁、醋等)。避免使用含酸或氯的清洁产品。

蓄电池点火

本燃气灶由1.5伏电池对自动点火系统供电。如果自动点火无法正常工作，检查燃气灶下的电池盒，确保电池位置正确。如有必要，请更换电池（见图9第9页）。在自动点火失败的情况下，可用火柴或打火机点燃燃烧器。

燃烧器和锅直径的选择

在控制面板上，每个旋钮的附近，会标注对应控制的燃烧器。根据使用锅的直径和热负荷来选择燃烧器。

平底锅直径建议使用的燃烧器如下：

燃烧器类型	平底锅直径 (cm)
辅助燃烧器	8 to 14
主燃烧器	20 to 26

平底锅的直径必须与燃烧器的热负荷相适应，这一点非常重要。使用过程中，需要调整控制旋钮，以确保火焰不会从锅底探出（见图2）。

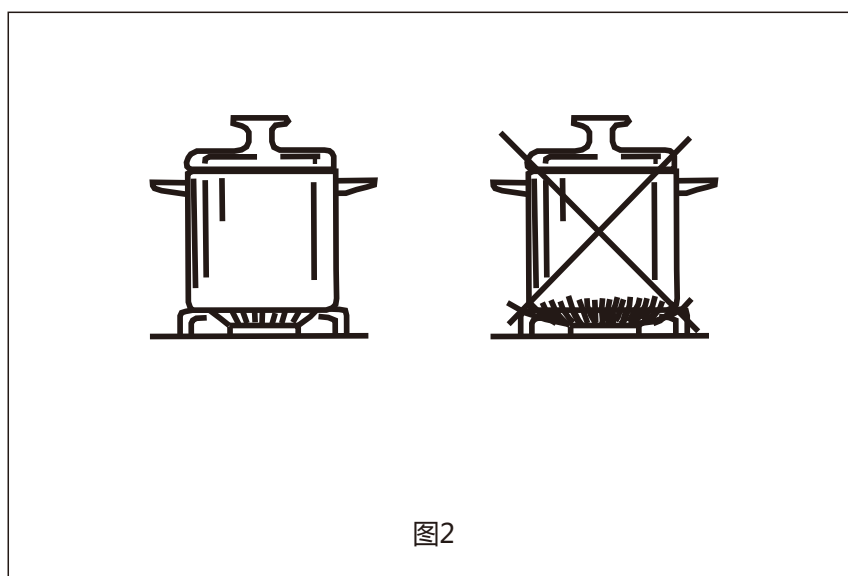

4.如何使用燃气灶

燃烧器

通过调节控制旋钮到以下对应位置，可以控制进入燃烧器的气体流量。（见图1）

- 关闭（关闭阀）
- 🔥🔥 大火（最大孔径或气流）
- 🔥 小火（最小孔径或气流）

火焰大小取决于对应燃烧器控制旋钮的位置。



烹饪的开始阶段，应将燃烧器设置为大火，快速煮沸烹饪食材。煮沸之后，将控制旋钮转至小火，使其缓慢升温，保持煮沸状态。其它火焰大小可通过将旋钮定位在大火和小火之间来实现。切勿在大火和关闭位置之间调整火焰大小。

点燃燃烧器

该燃气灶有自动点火系统和熄火保护装置。通过以下步骤点燃燃烧器：

- a. 按压并逆时针方向旋转对应的控制旋钮至大火位置，燃烧器即被点燃。
- b. 在这个位置，按住控制旋钮5秒，让火焰加热热电偶。
- c. 此时，松开旋钮，火焰保持点燃状态。
- d. 转动控制旋钮，调节到需要的火焰大小。
- e. 如果无法点燃，将控制旋钮顺时针旋转到关闭位置然后重复步骤a到步骤c。
- f. 完成烹饪后，顺时针转动控制旋钮到关闭位置。

3.燃气灶的型号和零件

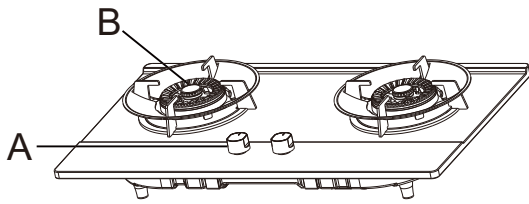

FH-GS6520 SVSS

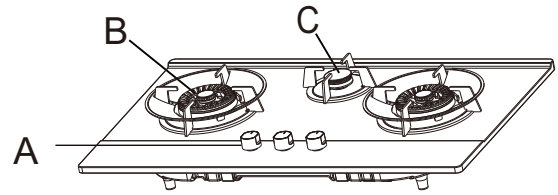

FH-GS6530 SVSS

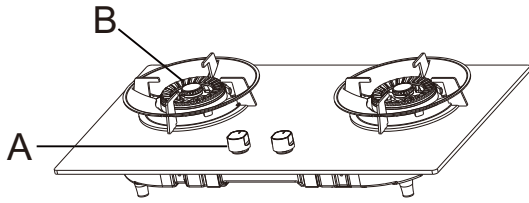

FH-GS6520 SVGL
FH-GS6528 SVGL

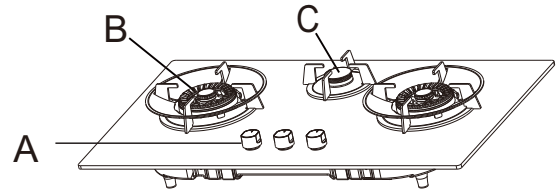

FH-GS6530 SVGL

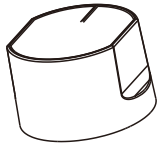

A.控制器旋钮

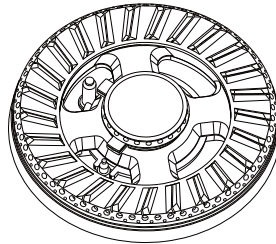

B 主燃烧器

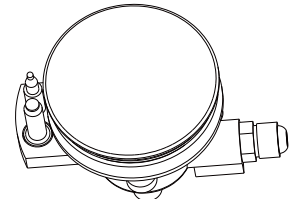

C 辅助燃烧器

表1 - a) 在30毫巴下使用液化石油气/G30气体时喷嘴直径和燃烧器的特性

燃烧器类型	额定热负荷 (kW)	外环喷嘴直径 (mm)	内环喷嘴直径 (mm)
主燃烧器	5.0	0.98	0.48
辅助燃烧器	1.1	0.53	—

表1 - b) 在10毫巴下使用人工煤气/G110气体时喷嘴直径和燃烧器的特性

FH-GS6520 SVGL / FH-GS6528SVGL / FH-GS6530 SVGL

燃烧器类型	额定热负荷 (kW)	外环喷嘴直径 (mm)	内环喷嘴直径 (mm)
主燃烧器	3.8	2.40	1.10
辅助燃烧器	1.1	1.45	—

FH-GS6520 SVSS / FH-GS6530 SVSS

燃烧器类型	额定热负荷 (kW)	外环喷嘴直径 (mm)	内环喷嘴直径 (mm)
主燃烧器	4.1	2.60	1.10
辅助燃烧器	1.1	1.45	—

2.钢化玻璃燃气灶警告标志



不得在锅和支架之间放置任何东西，如聚火圈、石棉垫等，以免损坏燃气灶。

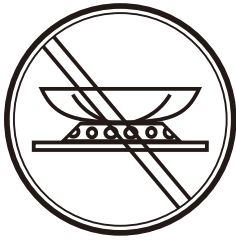

切勿移开锅支架并用锅圈架围住燃烧器，因为这会集中热量，并有可能将热量转移到玻璃面板上。

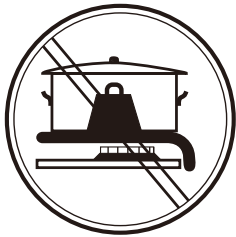

禁止使用使锅支架弯曲或引导火焰转向玻璃面板的超重大锅。

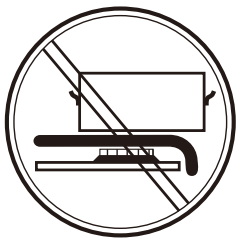

将锅置于燃烧器的中央位置，使其稳定，不要将锅悬空。



仅使用由制造商提供或推荐的锅支架。

亲爱的客户：

感谢您选择了FUJIOH的产品。

本手册中提供的安全注意事项和建议是为了维护您自身的安全。请保存本小册子，以备日后使用及维修燃气灶时参考。

该燃气灶仅供家庭使用，严禁用于其它用途。因燃气灶使用不合理、错误或不当造成的损害，制造商不承担任何责任。燃气灶安装和操作之前，请仔细阅读并理解说明书。

1.重要安全预防措施和建议

- a. 从纸箱中取出燃气灶，检查是否存在人为损坏。如有疑问，切勿自行安装/操作燃气灶，并与供应商联络以获得专业意见。
- b. 严禁改造燃气灶。
- c. 燃气灶应安装在通风良好的房间，安装位置应符合当地规定。
- d. 烹饪结束之后，确保控制旋钮被拧回关闭位置并关闭燃气总阀门。
- e. 如果14岁及以上的儿童知道如何使用燃气灶，并能够意识到使用不当可能造成危险，那么可使用该燃气灶。
- f. 使用该燃气灶时，切勿接触被火焰加热的燃气灶部位。注意的是在燃气灶关闭后，这些部件仍保持高温并会持续一段时间。
- g. 烹饪时千万不要让燃气灶无人看管。
- h. 严禁用水扑灭灶具上的火。
- i. 如果燃气灶使用时间过长，有必要开更多的窗户进行通风。
- j. 如果燃气灶意外熄火，请关闭燃气灶并且至少等一分钟后再尝试重新打火。
- k. 开始使用灶具时，可能会产生微量烟雾及气味，使用几次后，烟雾及气味会自动消失，这是正常并且无害的。

目 录

1.重要安全预防措施和建议	1
2.钢化玻璃燃气灶警告标志	2
3.燃气灶的型号和零件	3
4.如何使用燃气灶	4
5.清洁和维护	6
6.电池安装	9
7.安装说明	10
8.进气连接	13
9.燃气灶故障处理	14

-FUJIOH-

嵌入式燃气灶
使用/安装说明书

FH-GS6520 SVSS
FH-GS6530 SVSS
FH-GS6520 SVGL
FH-GS6528 SVGL
FH-GS6530 SVGL

使用本产品前，请仔细阅读本说明书