

Major Parts				
No	Parts	Material	Finish	Color
1	Hood front plate	Glass		
2	Hood frame	Stainless steel	No,4	
3	Oil panel	Stainless steel	No,4	
4	Body	Galvanized steel		Silver metallic
5	Rectifier baffle panel	Stainless steel	No,4	
6	Filter	Galvanized steel(Aqua Slit Filter,1 layer)		
7	Fan motor	4 Pole capacitor motor,class F		
8	Switch	Static electrical switch(On/Off,Low,Med,Hi,Timer,Light)		
9	Power supply cord	Cabtire cable		
10	Lighting	LED(Daylight white color),1.5W × 2pc		
11	Oil tray	Polycarbonate		
12	Recycling Device	Galvanized steel		Silver metallic

- Accessories
- ST4.2×9.5 Flat head screw . . . . . 6pcs
  - ST5×40 Wood screw . . . . . 7pcs
  - Plastic expansion pipe . . . . . 7pcs
  - ST4.2×9.5 Cross recessed flat head screw . . . . 4pcs

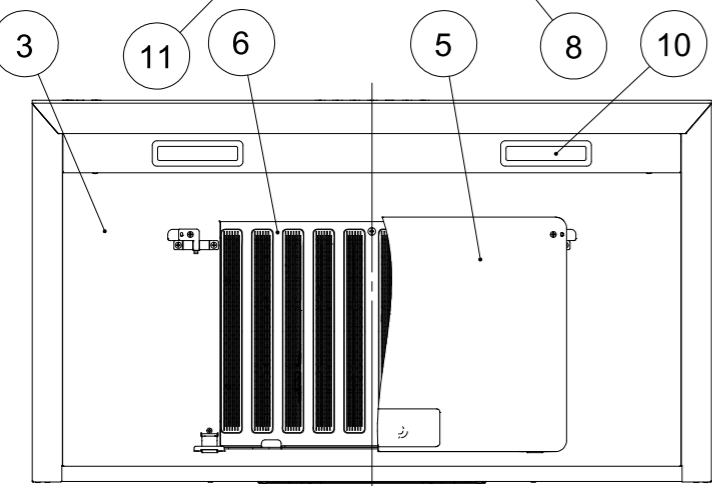
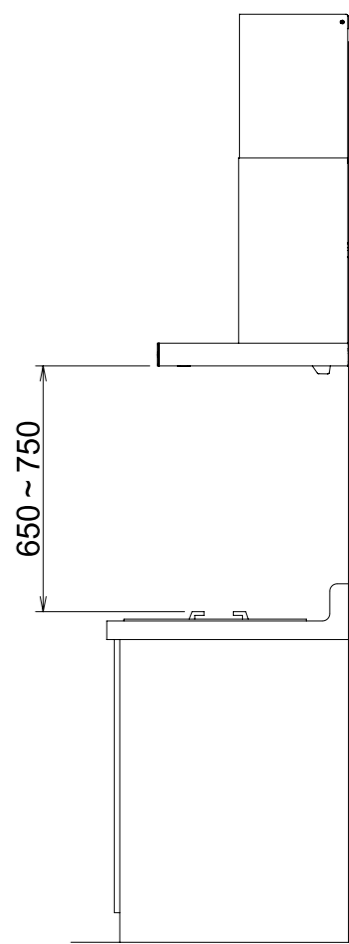
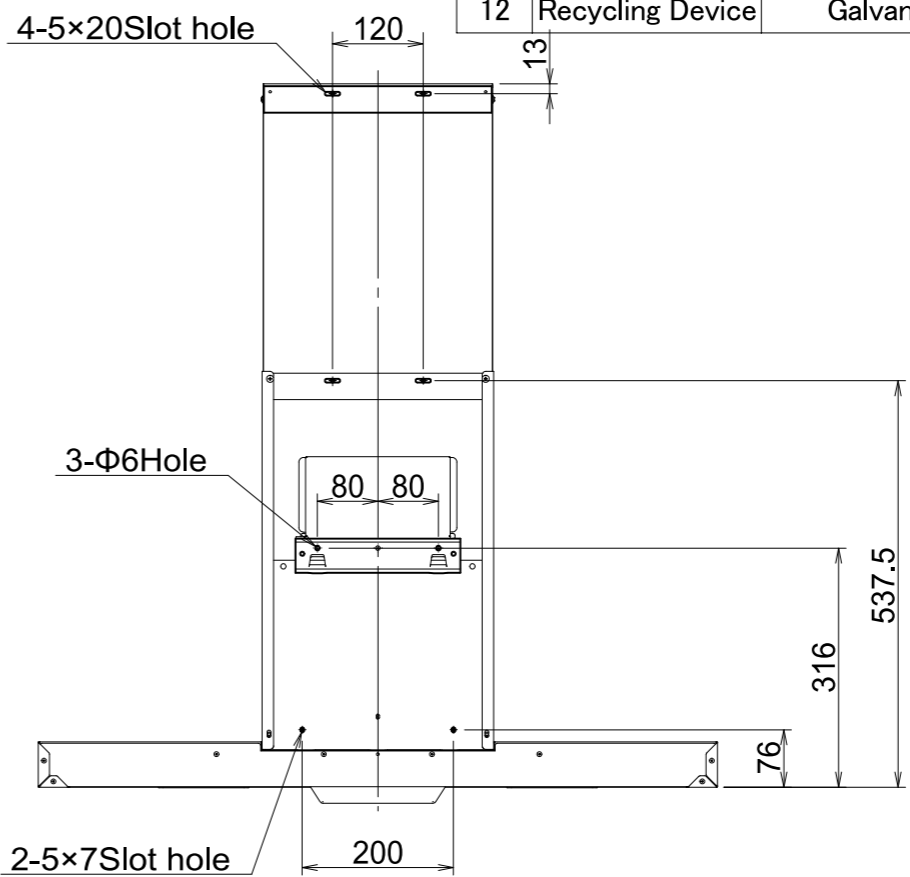
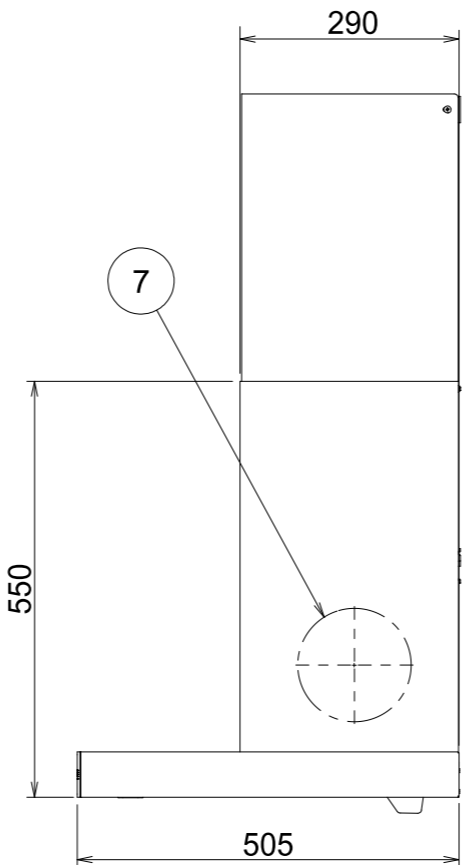
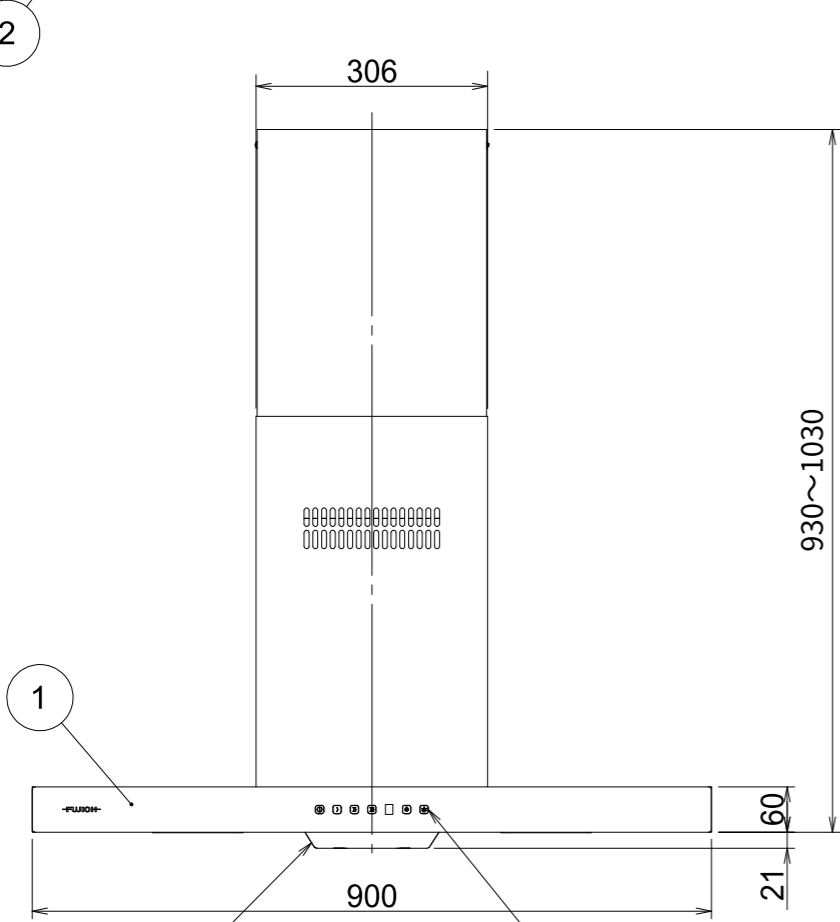
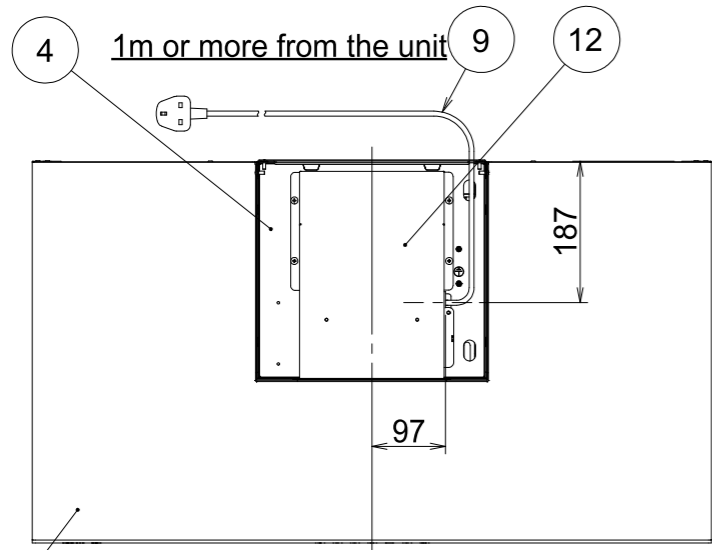

Specifications								
Model	Voltage (V)	Speed	Frequency (Hz)	Power consumption (W)	Airflow(m³/h)		Sound (db)	Weight (kg)
					0Pa	-		
FR-MT1990R	220	Hi	50	126	260	-	56	16.5
		Med		117	205	-	50	
		Low		99	120	-	39	
	230	Hi		134	270	-	56	
		Med		123	220	-	52	
		Low		104	130	-	40	
	240	Hi		143	270	-	57	
		Med		128	230	-	53	
		Low		114	140	-	41	

Motor class	4 Pole capacitor motor	insulation resistance	Over 10MΩ (500Vmegger)	Withstanding voltage	AC1000V for 1min	Insulation class	F
-------------	------------------------	-----------------------	------------------------	----------------------	------------------	------------------	---

Airflow measured by JIS C9603 chamber method

FR-MT1990RGCM	Champagne metallic glass /Stainless steel		
FR-MT1990RGBK	Black glass /Stainless steel		
Model	Product code	Color	Note
Created date	1/8/2019	Product category	Cooker Hood
Updated date	19/10/2022	Model	FR-MT1990R
<b>-FUJIOH-</b>		Scale	1/10
Product outline drawing			

Mark	Revised record	Date
△	Change the length of the slide duct	16/10/2020
△	Standard installation height drawing change	19/10/2022

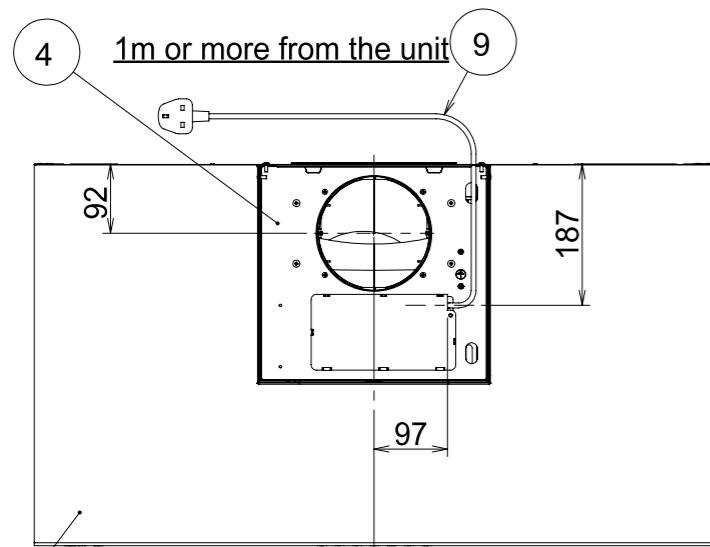

Accessories

ST4.2×9.5 Flat head screw	6pcs
ST5×40 Wood screw	7pcs
Plastic expansion pipe	7pcs

Major Parts				
No	Parts	Material	Finish	Color
1	Hood front plate	Glass		
2	Hood frame	Stainless steel	No.4	
3	Oil panel	Stainless steel	No.4	
4	Body	Galvanized steel		Silver metallic
5	Rectifier baffle panel	Stainless steel	No.4	
6	Filter	Galvanized steel(Aqua Slit Filter,1 layer)		
7	Fan motor	4 Pole capacitor motor,class F		
8	Switch	Static electrical switch(On/Off,Low,Med,Hi,Timer,Light)		
9	Power supply cord	Cabtire cable		
10	Lighting	LED(Daylight white color),1.5W × 2pc		
11	Oil tray	Polycarbonate		

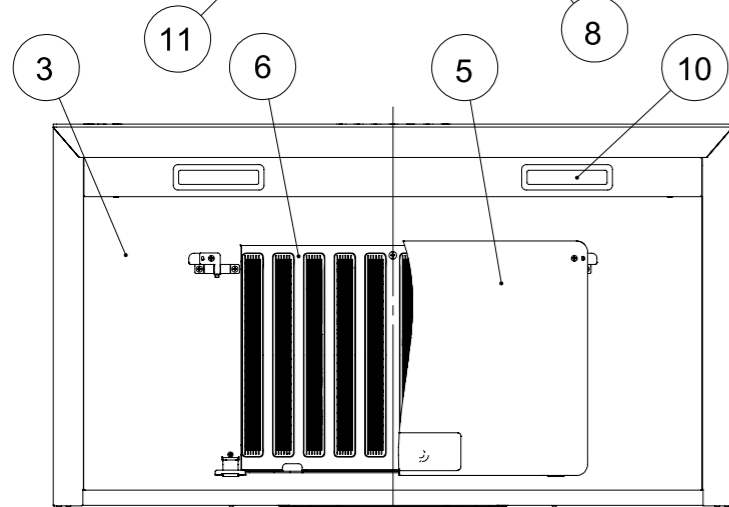
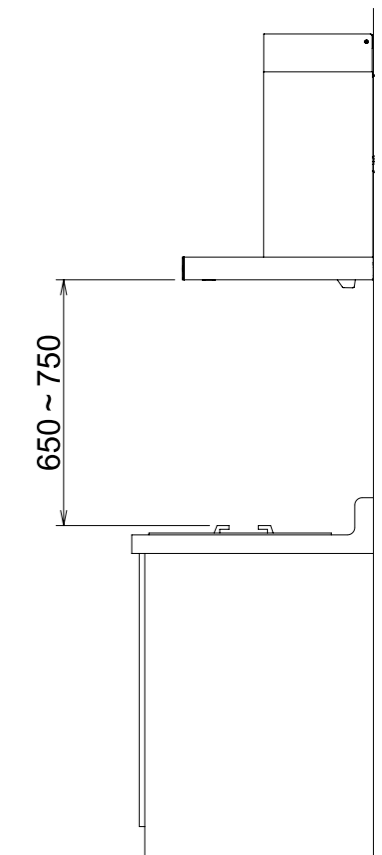
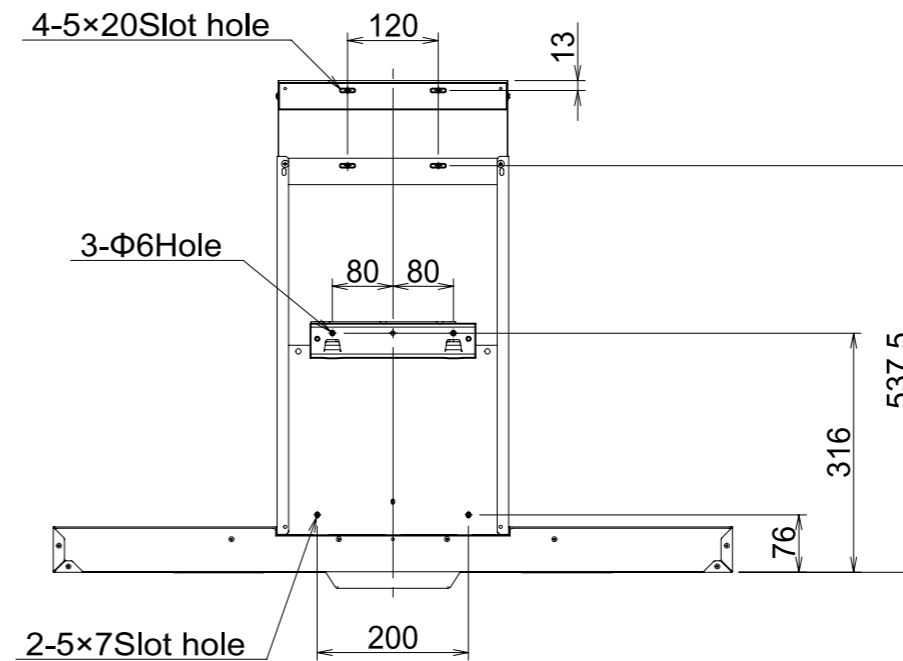
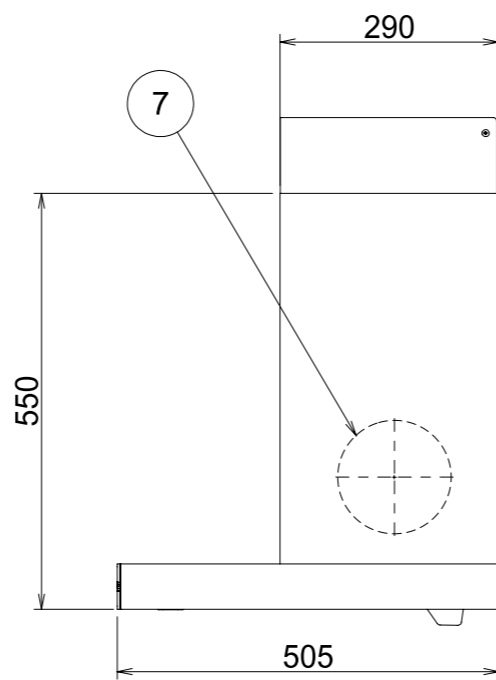
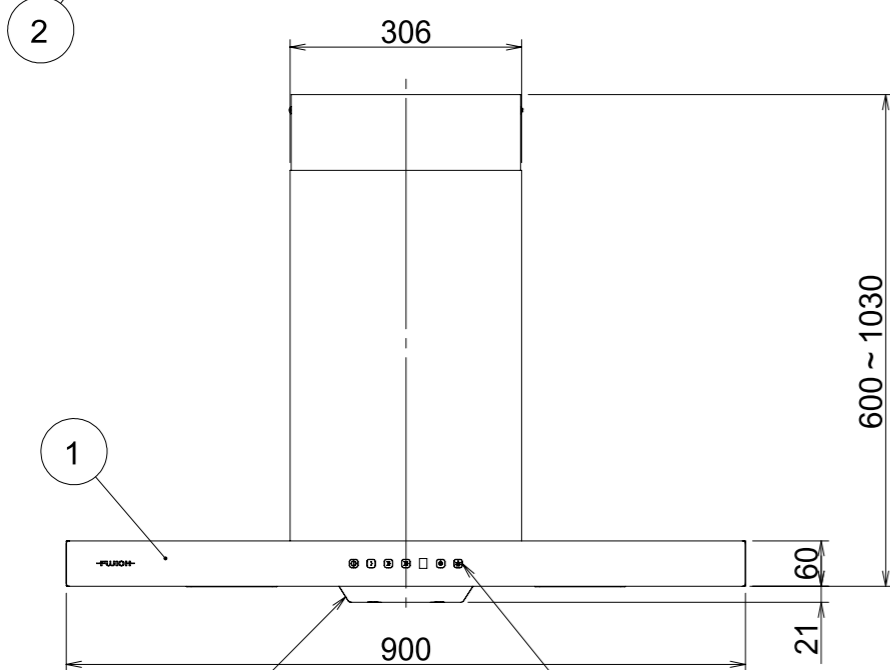

Specifications								
Model	Voltage (V)	Speed	Frequency (Hz)	Power consumption (W)	Airflow(m <sup>3</sup> /h)		Sound (db)	Weight (kg)
					0Pa	-		
FR-MT1990V	220	Hi	50	195	570	-	50	16.5
		Med		146	410	-	42	
		Low		106	255	-	32	
	230	Hi		211	600	-	51	
		Med		158	440	-	44	
		Low		114	270	-	34	
	240	Hi		226	620	-	52	
		Med		170	465	-	45	
		Low		121	285	-	35	

Motor class	4 Pole capacitor motor	insulation resistance	Over 10MΩ (500Vmegger)	Withstanding voltage	AC1000V for 1min	Insulation class	F
-------------	------------------------	-----------------------	------------------------	----------------------	------------------	------------------	---

Airflow measured by JIS C9603 chamber method

FR-MT1990VGCM	---	Champagne metallic glass /Stainless steel	---
FR-MT1990VGBK	---	Black glass /Stainless steel	---
Model	Product code	Color	Note
Created date	1/8/2019	Product category	Cooker Hood
Updated date	19/10/2022	Model	FR-MT1990V
<b>-FUJIOH-</b>		Scale	1/10
Product outline drawing			

Mark	Revised record	Date
△	Standard installation height drawing change	19/10/2022