

WATER HEATER/ FZ-WH50

INSTANT SERIES

-FUJIOH-

5 WATER HEATER
LIMITED WARRANTY*



FEATURES

01/ Performance



90° Stop Valve with Built-in Filter
Enjoy higher water flow rate and cleaner water



Stepless Power Control
Shower at your ideal shower temperature



Maintenance-free with Brushless Design*
No carbon brush to change and enjoy cleaner water



Silent Operation#
Silent operation using DC pump versus AC pump



Powerful Flow#
Deliver powerful flow yet save up to 70% energy

(*For models with Brushless DC Silent Inverter Pump only)

02/ Safety



Fire Retardant Heater Tank
Peace of mind with fire retardant VO material that complies to UL-94 grade



Auto Flow Sensor Switch
Avoid dry burn by shutting off heater when water flow is too low



Double Function Thermostat
Auto reset thermostat when water temperature exceeds safe limit



Anti-Leak Water Tank
Avoid scalding by withstanding water with high pressure



IP25 Splash Proof Protection
Protect against water and dust



Insulated PVC Hose
Extra safety with insulated PVC hose and non-conductive stop valve

03/ Comfort



180° Swivel Diverter Spout^
3-in-1 spout with swivelable diverter for extra convenience



Adjustable Rain Shower Height^
Extendable by 1 feet to bath at your preferred height

(^For models with Rain Shower Set only)

A hassle-free water heater

さざ波シリーズ

Manufactured to enable personal control of the shower temperature by a turn of the control while allowing you to beat the unbearable climate swings.

Enjoy silent operation, powerful flow and experience a new degree of comfort while showering. Your shower experience will never be the same!

5 MULTI SPRAY HANDSHOWER WITH ANTI-TWIST HOSE



01/ Comfort 02/ Maxi 03/ Combo 04/ Misty 05/ Massage

*5 years warranty for heating element • 1 year warranty for other parts
Warranty Terms and Conditions apply

COLORS

01/ Hand Shower Set Type



BK/ Black (Matt)



W/ White (Glossy)

02/ Rain Shower Set Type



BK/ Black (Matt)



W/ White (Glossy)

INSTALLATIONS

01/ Hand Shower Set Type

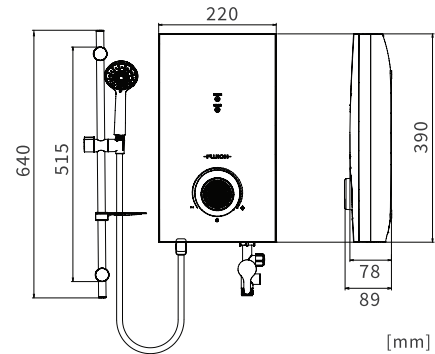

[mm]

02/ Rain Shower Set Type

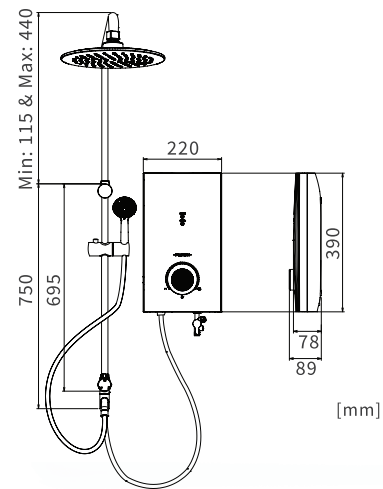

[mm]

SPECIFICATIONS

Model Name	FZ-WH5033N	FZ-WH5033D	FZ-WH5033NR	FZ-WH5033DR
Equipment				
Water Connection [mm/inch BSP]	15 or 1/2	15 or 1/2	15 or 1/2	15 or 1/2
Brushless DC Silent Inverter Pump	No	Yes	No	Yes
180° Swivel Divert Spout	No	No	Yes	Yes
Adjustable Rain Shower Height	No	No	Yes	Yes
Performance				
Minimum Water Flow Rate [Liter/min]	2	2	2	2
Maximum Water Pressure [kPa]	380	380	380	380
Minimum Water Pressure [kPa]	20	20	20	20
Power, Voltage				
Voltage [V/Hz]	230/50	230/50	230/50	230/50
Available Power [kW]	3.3	3.3	3.3	3.3
Accreditation				
Safety Standard	IEC	IEC	IEC	IEC
ROSH	ROSH COMPLIANT	ROSH COMPLIANT	ROSH COMPLIANT	ROSH COMPLIANT
ISO Certified Manufacturer	ISO 9001:2015	ISO 9001:2015	ISO 9001:2015	ISO 9001:2015
Dimensions and Weight				
Dimensions of Heater [mm]	W220 x H390 x D89	W220 x H390 x D89	W220 x H390 x D89	W220 x H390 x D89
Net Weight(Heater only) [kg]	1.3	1.6	1.3	1.6
Gross Weight(Heater+Shower Set only) [kg]	2.6	2.9	4.5	4.8

