

-FUJIOH-

Built-in Multifunctional Steam Oven

Instruction Manual

FV-ML71

Please read this manual carefully
before using this appliance.

Contents

Important Notes -----	Page 1
General Warnings-----	Page 1
Power Connections -----	Page 3
Button Cell -----	Page 4
Installation Instructions-----	Page 5
Technical Specification -----	Page 7
Oven Overview -----	Page 7
Accessories -----	Page 8
Operating the Multifunctional Steam Oven-----	Page 8
Cleaning Water Reservoir-----	Page 8
Oven Settings-----	Page 10
Cooking Function Descriptions -----	Page 17
Recommended Steaming Times -----	Page 19
Recommended Baking & Grilling Times -----	Page 20
Cleaning and Maintenance -----	Page 21
Trouble Shooting-----	Page 24
Circuit Diagram -----	Page 25
Disposal -----	Page 26

Important Notes

Dear customer,

Thank you for choosing our product. Before unpacking it, please read this manual carefully to operate and install your appliance safely and correctly.

- This appliance is designed to be handy for any adult to use at home. Do not allow children to play with it.
- Children need to be supervised when the product is in operation so that they do not go near it.
- This product must be connected in accordance with current electrical regulations. Fixed wiring installation is to be done only by an authorised electrician.
- Before maintenance or cleaning of the product, disconnect the appliance from the mains and wait for the oven to cool down first.
- For any repairs, always contact authorised Customer Service Center and ask for original spare parts. Repairs by untrained personnel may lead to damage and void the warranty.
- Please flush the built-in reservoir before using if the multifunctional steam oven has not been used for more than a month.

General Warnings

- Ensure that the appliances is switched off before replacing the lamp to avoid the possibility of electrical shock.
- The appliance and its accessible parts become hot during use. Care should be taken to avoid touching heating elements. Children less than 8 years of age shall be kept away unless continuously supervised.
- Do not use harsh abrasive cleaners or sharp metal scrapers to clean the oven door glass since they can scratch the surface, which may result in shattering of the glass.
- A steam cleaner should not to be used.
- Fixed wiring must be protected.

- The door should be situated more than 85 mm above floor after installation of the oven.
- Surfaces of storage drawer can get hot.
- If the supply cord is damaged, it must be replaced by a special cord or assembly available from the manufacturer or service agents.
- In order to avoid a hazard due to inadvertent resetting of the thermal cut-out, this appliance must not be supplied through an external switching device, such as a timer, or connected to a circuit that is regularly switched on and off by the utility.
- This appliance can be used by children aged from 8 years and above and persons with reduced physical, sensory or mental capabilities or lack of experience and knowledge if they have been given supervision or instruction concerning use of the appliance in a safe way and understand the hazards involved. Children shall not play with the appliance. Cleaning and user maintenance shall not be made by children without supervision.
- **WARNING:** Unattended cooking on a hob with fat or oil can be dangerous and may result in fire.

NEVER try to extinguish a fire with water, but switch off the appliance and then cover flame e.g. with a lid or a fire blanket.

WARNING: Danger of fire: do not store items on the cooking surfaces.

- **WARNING** – If the surface is cracked, switch off the appliance to avoid the possibility of electric shock.
- **WARNING** – Accessible parts may become hot when the grill is in use. Children should be kept away.
- Excessive spillage must be removed before cleaning.
- The oven must be switched off before removing the guard.
- After cleaning, the guard must be replaced in accordance with the instruction.

- An additional protective means to avoid contact with the oven door is available. This part should be fitted when young children are likely to be present.
- Metallic objects such as knives, forks, spoons and lids should not be placed on the hob surface since they can get hot.
- If during the test of Clause 11, the temperature rise at the center of the internal bottom surface of a storage drawer exceeds that specified for handles held for short periods in normal use, the instruction shall state that these surfaces can get hot.
- The oven must be switched off before removing the guard and that, after cleaning, the guard must be replaced in accordance with the instructions.
- The appliance must not be installed behind a decorative door in order to avoid overheating.
- Disconnection of the appliance after installation, by accessible plug or a switch in the fixed wiring.
- This appliance should be connected to a circuit which incorporates an isolating switch which can be accessible by the user after installation providing full disconnection from the power supply. The disconnection may be achieved by incorporating a switch in the fixed wiring in accordance with the wiring rules.
- Children less than 8 years of age shall be kept away unless continuously supervised.

Power Connections



IMPORTANT!

THE APPLIANCE MUST BE CONNECTED IN ACCORDANCE WITH THE CURRENT ELECTRICAL RULES AND REGULATIONS. INSTALLATION IS TO BE DONE ONLY BY AN AUTHORISED ELECTRICIAN.



IMPORTANT!

THIS APPLIANCE MUST BE EARTHED.

- Means for disconnection in the form of an isolation switch must be incorporated into the fixed wiring .

- The insulation switch can easily be reached after the oven is installed.
- Please check and confirm that the electric meter, circuit breaker, power supply cable and socket are adequate to withstand the maximum power load of the product. (Refer to the technical specifications for maximum load.)
- Earthing should be tested regularly to ensure that it is working properly.
- After connection to the mains, please check that the supply cable does not overheat.
- Never use reductions, shunts or adaptors that can cause overheating or burning.
- The supply cable must be positioned as much that it is not exposed to any external heat source exceeding 50°C at any point or its length.

⚠ IMPORTANT! The manufacturer shall not be liable for any direct or indirect damage caused by faulty installation. The installer must ensure that the product installation and power connection complies with all local and general regulations in force.

Button Cell

There is a button cell on the back of display board,

Button cell Model No.: CR2032

To replace the button cell,

Unplug the appliance, open the top panel, the button cell on the back of the display board.

Lightly release the pin which hold the button cell, take it out, replace by the new button cell. Make sure the + side uppermost

- Non-rechargeable batteries are not to be recharged;
- Different types of batteries or new and used batteries are not to be mixed;
- Batteries are to be inserted with the correct polarity;
- Exhausted batteries are to be removed from the appliance and safely disposed of;
- If the appliance is to be stored unused for a long period, the batteries should be removed;
- The supply terminals are not to be short-circuited

Installation Instructions

When designing the cabinet ensure that:

- The cabinet openings are as Diagram 1.
- There is a supporting panel underneath for the oven to sit on.
- There is adequate space around the appliance for air to circulate.
- The materials, laminates, edging and adhesive used to construct the cabinet withstand temperature up to 120°C.

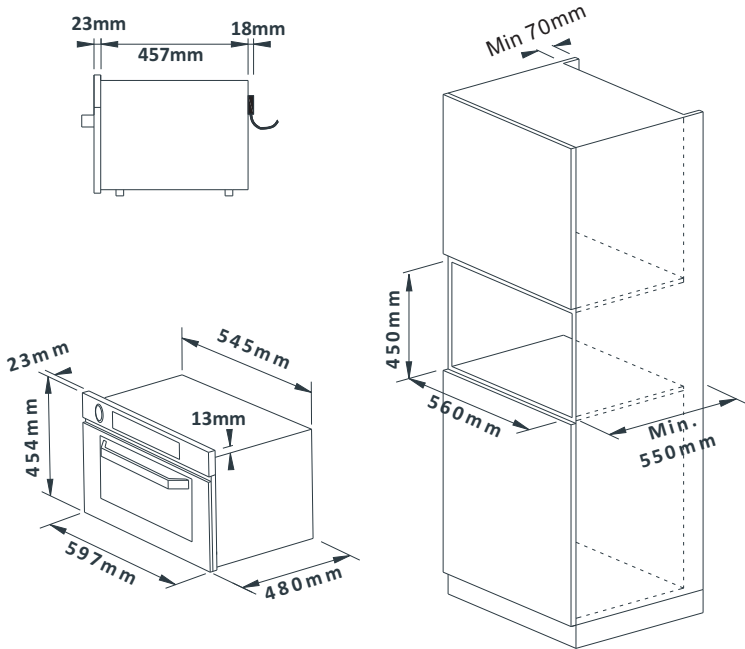

Diagram 1

- For the most efficient air circulation, the cabinet construction should incorporate a recessed rear panel (min. 70mm) which allows the hot air to rise through the space behind the cabinet while drawing fresh air through the space beneath the oven door.
- There must be no rear panel directly behind the oven itself so that air can circulate freely. Refer Diagram 2.

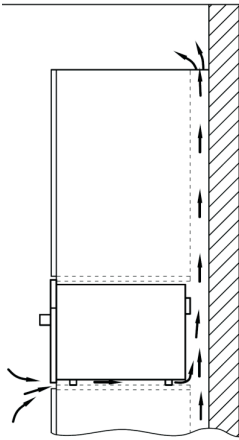

Diagram 2

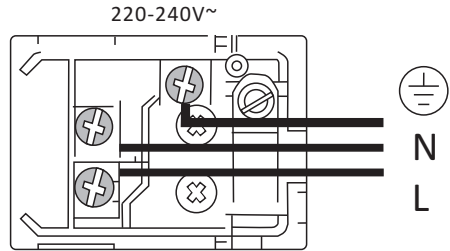

Diagram 3

- Fit the appliance to the cabinet by inserting the mounting screws into the 4 holes that can be seen on the oven frame when the door is open. Refer to Diagram 4.

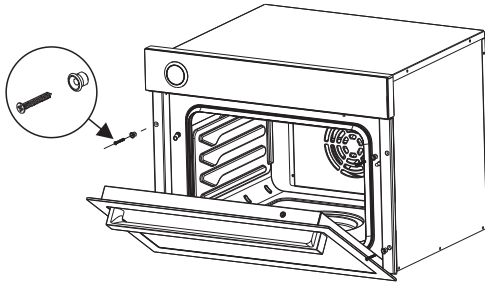

Diagram 4

- Ensure that the oven is fitted firmly in place as described above and properly insulate the electrical connection to prevent the possibility of it coming into contact with any metal parts. All live and insulated parts must be secured in such a way that they can only be removed by using tools.

- Do not switch on the appliance until it has been fully and correctly installed.

⚠ IMPORTANT!

The power socket must be connected to a switch with earth leakage protection. If the power cable is damaged, immediately contact a qualified electrician to have it replaced.

Technical Specifications

Product	Built-in Multifunctional Steam Oven
Model Number	FV-ML71
Voltage (AC)	220 - 240V~
Frequency	50 - 60Hz
Rated Power	2200W
Oven Capacity	45 L

Oven Overview

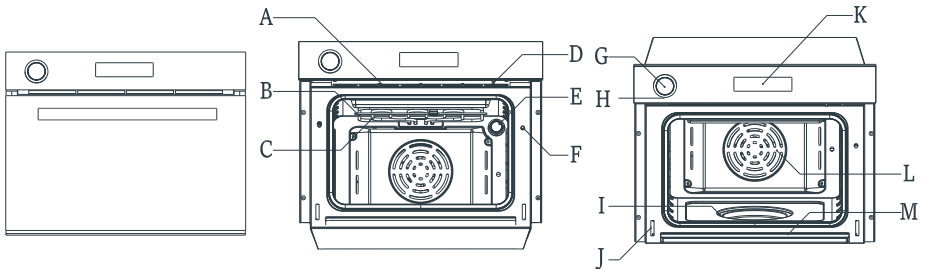

- A - Oven Vent
- B - Top Heating Element
- C - Grill
- D - Door-Lock
- E - Oven Lamp
- F - Door Switch

- G- Water Reservoir Inlet
- H- Water Reservoir Outlet
(push G open the water inlet point and the outlet point located underneath.)
- I- Water Heating Element
- J- Hinge Slot
- K- Control Panel Display
- L- Fan Forced Heating
- M- Gutter

Accessories

S/S Tray1		Sponge	
S/S Tray2		Water Jug	
Small Rack		Installation Rubbers	
Baking Accessories Set		Screws	

Operating The Multifunctional Steam Oven

Before First Use

Before using the multifunctional steam oven for the first time, we suggest to :

- Remove and clean all accessories.
- Remove the special film covering the oven door glass (if there is any).
- Set the empty oven to heat each baking element - Fan Force, Grill, and Full Grill at maximum temperature for 45 mins. This is to remove any unpleasant smell caused by working residues.
- Let the oven cool down and clean the oven cavity with soapy water and wipe dry.
- Flush the built-in water reservoir **three times**. Refer to “Cleaning Water Reservoir” section.
- Lastly run the steaming function for 10 mins to flush and clean the rest of the steaming system.

Cleaning Water Reservoir

The built-in reservoir needs to be flushed 3 times to clean it and remove any unpleasant smell before it's first usage. Refer to the instructions below:

1. Connect the appliance to power and press the display screen to turn the oven on.
2. Push to open the Water Reservoir Inlet and use a suitable jug with 1L of water. Refer to Diagram 5.
3. Open the oven door and hold an empty jug below the Water Reservoir Outlet located under the Inlet point. Refer Diagram 6.

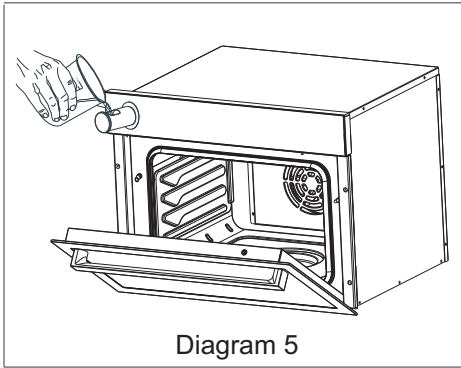

Diagram 5

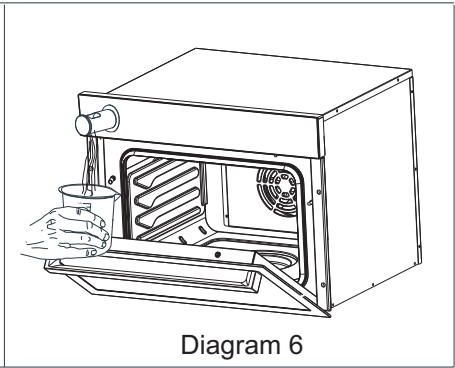



Diagram 6



WARNING: Use appropriate vessel to store the water coming out from the built in water reservoir cleaning. (The water outlet locates under the popup water inlet.)
Empty and cleaning the built in water reservoir after every use to clean.

4. Press  icon on the top left hand corner of display screen to discharge water. Keep the oven door open.



5. Continue discharging until the water reservoir is empty and repeat this process again twice.

⚠ IMPORTANT! Flush the built-in water reservoir before using if the oven has not been used for more than a week.

⚠ IMPORTANT! We recommend using filtered or distilled water to avoid the water system from getting blocked and stain build-up.

⚠ WARNING! Do not let children play near, around or with the oven.

Oven Settings

1. Plug in the oven, touch the display screen to turn on the oven.



Bake: Choose the cooking function/food to bake or grill the food.

Steam: Choose the food to steam cooking.

Unite: Choose the food you cook, and set the cooking for steaming first then grilling/baking to make the food juicy inside and crispy outside.

Recipe: There are some set recipes available to choose, so make the cooking get easier.

Setting: To set the date & time, language, latest version of the software, brightness and Wi-Fi connection.

Connect to internet: Press “Setting” icon, then press Wi-Fi to connect to internet; or press the Wi-Fi icon on the top right corner of homepage to connect to internet.

2. Bake Setting

You can choose the food you want to cook by pressing Bake icon.

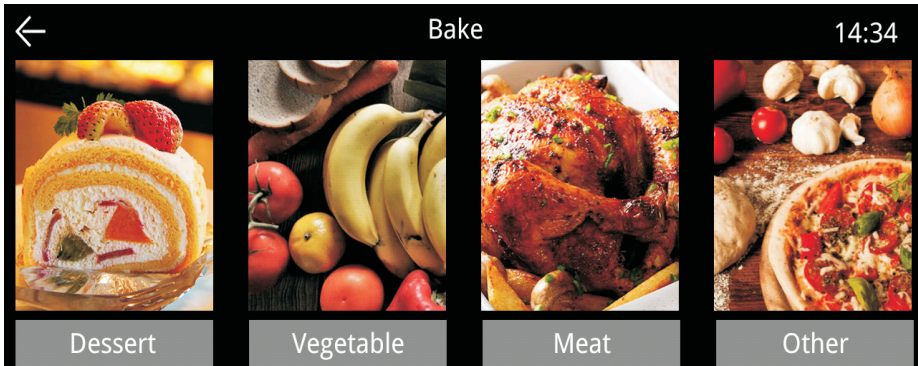

- When baking, adjust the cooking temperature and time.

When you choose the food you want to bake or grill, you can adjust the cooking functions, temperature and cooking time as your personal preference by sliding the numbers on the display.

After setting is completed, press  to start cooking.

There 8 different cooking functions to choose.

Slide or press the function icons to select the cooking function as per your preference.



After the oven starts baking, the display panel will constantly remain on, you can see the working time and current temperature.

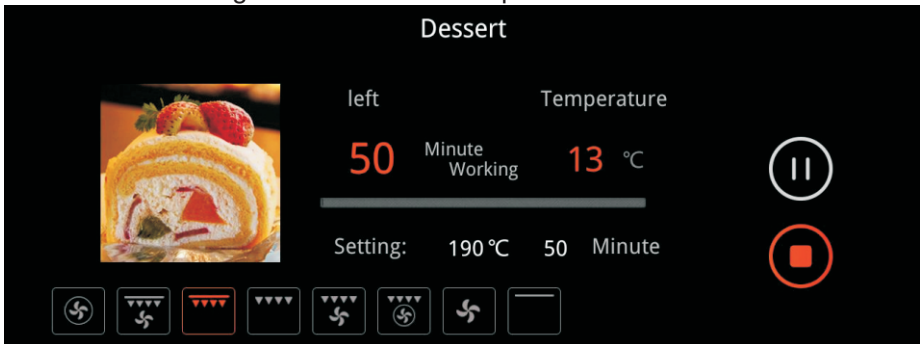

When the cooking is finished, the display will show as below, press "OK" to confirm and the lock will release.

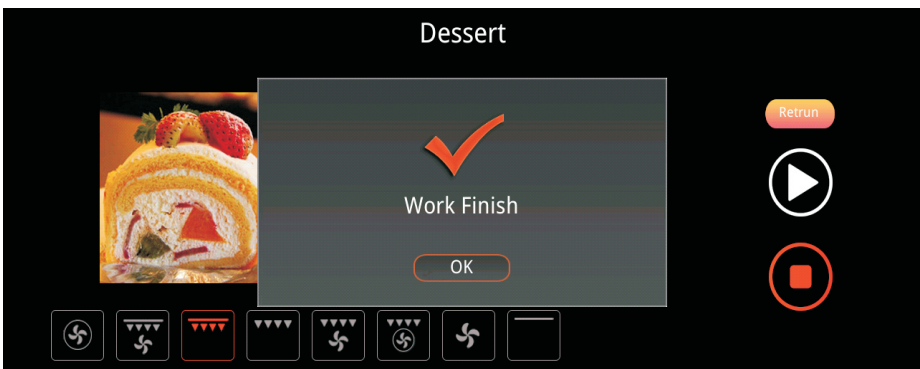

3. Steam Setting

- Select the kind food to steam, in the sub-menu you can select different foods.

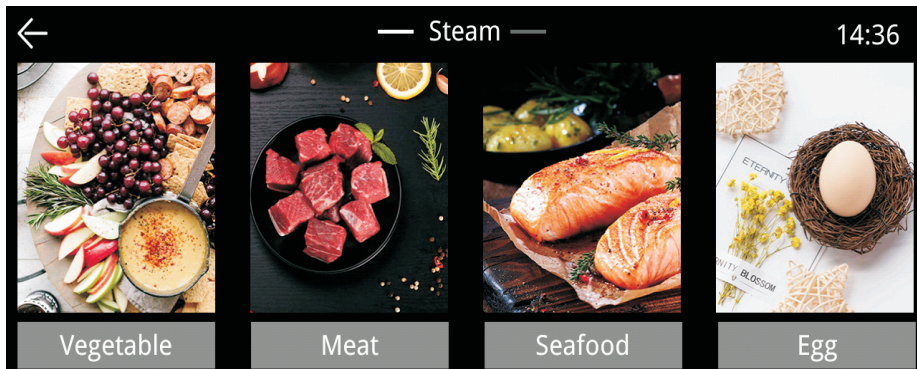

Sub menus:



- Adjust the cooking temperature and time.

The default setting of cooking time and temperature is displayed when the food to be cooked is selected, but you can also adjust the time and temperature as per your preference by sliding the numbers on temperature and time settings.

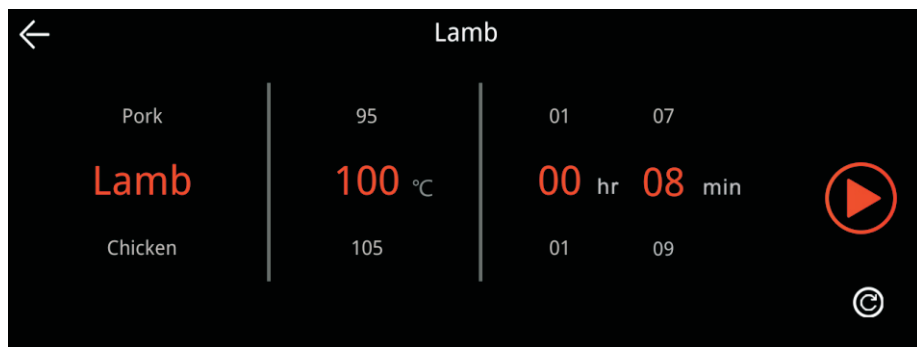

- When steaming.

After the oven start steaming, the display panel will always on, you can see the working time and current temperature.

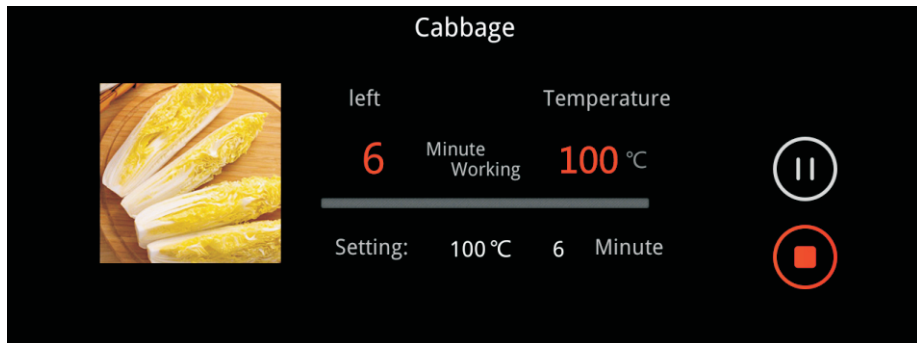

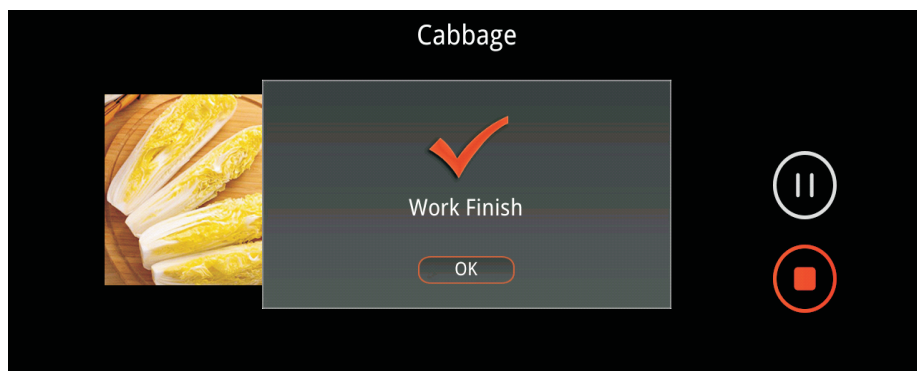

After the cooking finish, the display will show as below, press “OK” to confirm and the lock will release.



- Important Information on Steaming.

Operation, Cautions & Warnings

For safety, the oven door locking mechanism is automatically activated once cooking starts. To inspect the food while cooking, press  to pause cooking and unlock to door. To resume, close the door and press .

If the oven is still hot, steam will be released when the door is opened. Stay away from the appliance and wait until the steam has completely dissipates before attempting to remove the cooked food.

In the last 3 minutes of cooking, to reduce the amount of water remaining on the water heating element after cooking, the oven will cease pumping water onto the heating element. Any water that remains on the heating element will continue to be heated as normal till the time is up.

As a safety precaution, just as the cooking is about to end the oven will release some steam from the chamber through the oven vents. In the last minutes the temperature may drop off slightly if the water on the heating element is depleted and/or due to the venting. There may be water remaining on the heating element after cooking. The fan motor will continue to work for 15 minutes after cooking time has finished.

WARNING! The oven door surface temperature can go up to 55°C during the cooking process.

WARNING! When opening the door of a hot oven, open it gradually to allow the steam to slowly escape and avoid the risk of scalding.

4. Combination Cooking Setting – Unite Function

- Select the kind food to cook, in the sub-menu you can select different foods.

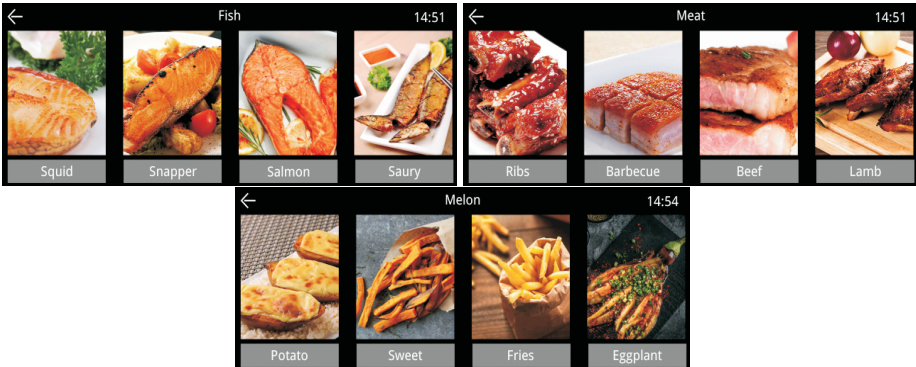

- Adjust the cooking temperature and time.

The default setting of cooking time and temperature is displayed when the food to be cooked is selected, but you can also adjust the time and temperature as per your preference by sliding the numbers on temperature and time settings.

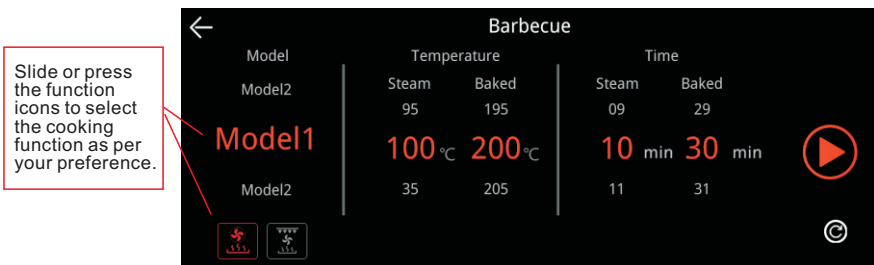

- When the oven is working.

After the oven starts cooking, the display panel will constantly remain on, you can see the working time and current temperature.



After the cooking is finished, the display will show as below, press “OK” to confirm and the lock will release.

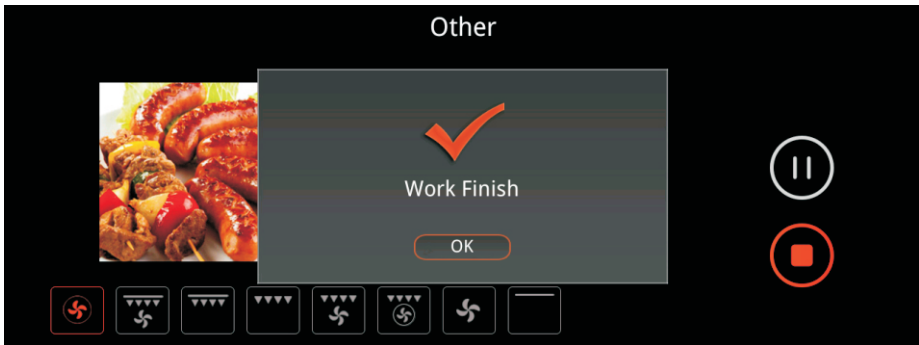

5. High Temperature Steam Function

- There is function for steaming with high temperature, which can be used for making stew, meat, or make the steaming time shorter the energy.

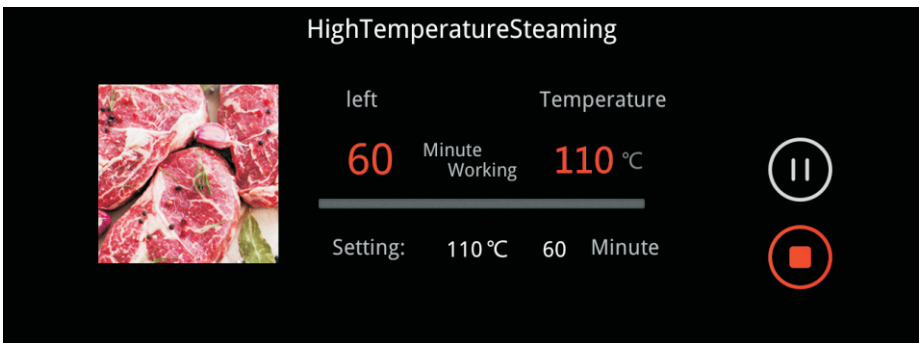

6. Recipes

- There are some recipes available with cooking steps to make cooking more easier and fun.

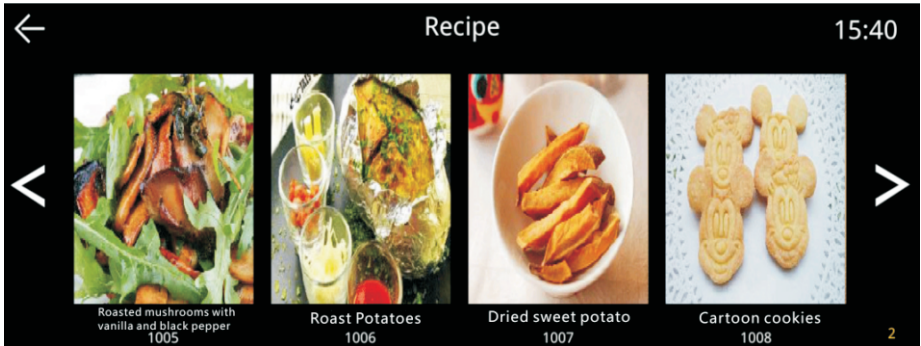





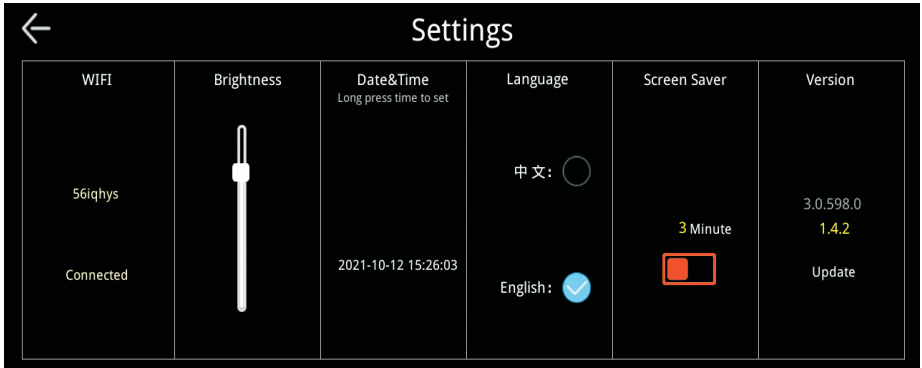



7. Settings

- In the settings, you can connect Wi-Fi, adjust the brightness of the screen, set the date and time, choose the languages (only available in Chinese and English) and update the software.





Cooking Functions Descriptions

- Grilling / Baking

Icon	Function	Descriptions
	Fan Forced Heating	The circular heating element and the fan comes into operation. Heat is distributed evenly to all levels. Several dishes can be cooked on different shelves. Fan forced model is ideal for baking, cooking large serves of food and cooking different dishes together.
	Full Grill + Fan	Both inner and outer part of the top heating element operates with fan assistance. The fan disperses the radiant heat from the elements. Suitable for browning food, whilst keeping it moist.
	Full Grill	Both outer and inner part of the top heating element operates. It is more suitable for grilling larger portions of foods then the half grill function.
	Half Grill	The inner top heating element operates. Provides direct heat to the top surface of the food. It is suitable for small portions of foods.
	Half Grill + Fan	With fan assisted, the inner top heating element is able to give a very generous coverage of the grill tray from rear to front. Suitable for cooking small portions of food.
	Half Grill + Fan Forced Heating	With inner top heating element, circular heating element and fan assisted, gives more even heat all around the chamber and gives the food with golden brown finish. Suitable for large portions of food.
	Defrost	The fan operates without the heating elements. Can be used to defrost frozen food. The required time for defrosting depends on the type and quantity of food, and the room temperature.
	Top Heat	Top outer heating element radiates heat down directly to your food, giving your food a golden brown finish. Also suitable for gentle cooking and reheating meals.

- Combination Cooking

Icon	Function	Descriptions
	Steam + Fan Forced Heating	Steaming cooking first, then following by fan forced heating to bake the food. More efficient cooking, it makes the food with crispy finish and keep moist inside of the food.
	Steam + Full Grill + Fan	Steaming cooking first, then following by the full grill with fan cooking. Shorting the whole cooking time, and the fan disperses the radiant heat from the elements. Suitable for browning food, whilst keeping it moist.

Recommended Steaming Times

Food	Temperature(°C)	Time (mins)
Vegeables		
Broccoli (small size)	100	6-8
Cauliflower	100	6-8
Cauliflower (small size)	100	6-8
Green Soya Bean	100	8-10
Pea	100	10
Potato (half cut without skin)	100	20-25
Potato (with skin)	100	30-35
Carrot (in pieces)	100	6-8
Asparagus	100	10-14
Meat & Sausage		
Chicken (whole)	100	20-25
Chicken in pieces	100	6-7
Sausage	90	5
Pork Rib	100	7-9
Pork	100	10-15
Fish		
Salmon Filets	100	7-10
Flatfish Filets	100	7-10
Bean		
Soaked Lentil	100	10-15
Dry Bean	100	22-25
Dry Lentil	100	20-22
Rice & Grain		
Wheat	100	10
Porridge	100	15-20
Whole Grain	100	16-35
Boil Egg		
Soft Boiled	100	5
Medium	100	5-6
Hard Boiled	100	8-10
Fruits		
Apple/Pear in Pieces	100	5
Cherry	100	5
Chinese Rhubarb	100	5
Chinese Stews	100	40-80

⚠ IMPORTANT! The above information is for reference only. Cooking times depend on the type of food, its consistency and volume. Initially, monitor the performance when you cook. Find the best settings (heat, cooking time etc.) for your cookware, recipes and quantities when you use this appliance.

Recommended Baking & Grilling Times

Food	Guide No.	Oven Temp.(°C)	Time (mins)
Food	2	200~225	Depends on qty
Slow-Cooking Roast	2	200~225	50~60
Fowl (Duck)	2	200~220	40~55
Poultry	1	200~225	Depends on qty
Fish	1	190~220	20~30
Pastries	Base only	160~200	15~20
Pizza	2	160~180	25~30
Veal Cutlet	3	190~220	20~30
Lamp Cutlet	3	190~220	20~30
Liver	3	190~225	10~12
Chopped Meat Roulades	3	190~225	12~15
Veal Heart	3	190~220	12~15
Roast In Net	3	190~220	20~30
Half Chicken	3	200~220	40~55
Fish Filet	3	190~220	12~15
Stuffed Tomatoes	3	190~220	10~15
Potatoes	3	180~220	40~60

⚠ IMPORTANT! The above information is for reference only. Cooking times depend on the type of food, its consistency and volume. Initially, monitor the performance when you cook. Find the best settings (heat, cooking time etc.) for your cookware, recipes and quantities when you use this appliance.

⚠ IMPORTANT! For the best result its recommended to preheat the oven before baking or grilling.

💡 USEFUL TIPS! When cooking meat with bones add 10–15 minutes.

💡 USEFUL TIPS! To save energy only open the oven door at absolute necessity. Additionally, the oven can be switched off some minutes before the cooking ends. The residual heat is enough to complete cooking.

Cleaning and Maintenance

Water Reservoir

IMPORTANT! Empty the built-in water reservoir after every use to prevent scale build-up.

Cleaning the Oven

Please read carefully and follow the guidelines described below. WARNING! Prior to cleaning or maintenance, always disconnect the power supply.

WARNING! Do not use a steam cleaner to clean the oven. Doing so may lead to damage of the oven control panel display and PCB boards.

IMPORTANT! Only use neutral detergents. Do not use abrasive products, abrasive cleaning pads or solvents.

Shelves and Trays

Wash and dry the shelves and trays after use.

Gutter

After steaming check if there is water present and sponge dry if necessary.

Door seal

Use warm soapy water and a sponge to clean and dry the seal after each use.

IMPORTANT! Replace the door seal with a new one if it becomes torn or damaged.

Oven Chamber

Clean the chamber after use with wet sponge soaked in neutral cleanser. Then use a soft cloth to wipe off. Most cooking residue can be removed this way. In some cases, white deposits or scales are built-up in the chamber due to use of hard water with high impurity contents. Use a cloth wetted with vinegar to wipe off this deposit.

Heating Element

The water heating element may have scale built-ups after a period of time, use warm water with 5% citric acid cleanser to remove scaling.

Glass Door

Use an appropriate glass cleanser to clean the steam oven glass door.

Removing the Oven Door

For easier cleanups, the oven door can be removed.

1. Open the oven door fully as shown in the figure below.
 2. Lift up and turn the small levers B located on the two hinges.
 3. Grip the door on the two outer sides and close it approximately half way.
 4. Pull the door towards you lifting it out of the hinge slot.
- To replace the door, ensure the seat D is hooked perfectly onto the edge of the hinge slot, and then reverse the above mentioned sequence.

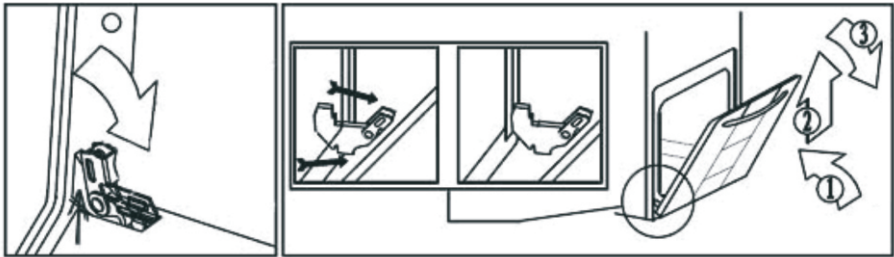
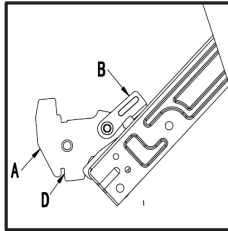

Stainless Steel Front Panel

Use a soft, not abrasive cloth with warm soapy water to clean the control panel and door panel of the oven. Dry the stainless steel surfaces with a soft dry cloth.

Use non-scratch cleaning agents to clean the stainless steel surface and always clean by following the grain direction.

WARNING! Do not use harsh chemicals, harsh cleaning agents or any abrasive material on the control panel. Doing so may remove the indicator markings which will not be covered by warranty.

WARNING! Do not use the steam cleaner, the warranty will not cover the damage by the steam cleaner.

WARNING! Do not use the cleaning agents which contains soda, acid, or chlorinum.

WARNING! Do not use cleaning sprayer, harsh abrasive cleaner or sharp metal scrapers to clean the oven, the harsh cleaners may scratch the surface.

NOTE! Allowing a stain to stay on the stainless steel surface for long periods may cause permanent damage to the stainless steel.

It is important that you clean the appliance after each use to prevent an accumulation of grease and avoid unpleasant odors.

Removable wire rack, bake tray, crumb tray (if applicable) can be washed, as normal kitchenware.

Let all parts and surfaces dry thoroughly prior to plugging oven in and using for another time.

Replacing the oven bulb

To avoid electric shock, the steam oven must be electrically disconnected, then unscrew the glass protection cap and the bulb, replacing it with another one suitable for high temperature 300°C.

It should be fit below points:

Voltage: 220-240V~ Power: 15W E14

Reassemble the glass cap and reconnect the oven.

Troubleshooting

The maintenance and service must be carried by a qualified service person.

NOTE! The manufacturer is not liable for any direct or indirect damage caused by unqualified service person or installer.

Problem	Possible Cause & Solution
The oven cannot be powered on.	Turn the main switch off. Remove the plug from the socket and check if the socket has power coming to it. If there is no power, contact an electrician to check it. If there is power, contact the service representative to check the oven.
When steaming the oven fails to heat up after starting.	Check if the oven door is closed properly. Check if there is adequate water in the reservoir. If both are ok, then the heating element fuse could be blown, contact the service representative to check the steam oven.
When steaming the oven takes too long to heat up.	Check if there is a thick layer of scale buildup on the heating element and clean if necessary. If this fails to solve the problem, contact the service representative to check the steam oven. Check if the door seal has been damaged. If so, contact the service representative to have it replaced.

Parameters

Model No.	FV-ML71	Rated Power	2200W
		Back Heating Element	1600W
Rated Voltage	220-240V~	Outer Top Heating Element	820W
Rated Frequency	50-60Hz	Inner Top Heating Element	1200W
Chamber Light	15W	Circulating Fan	30W
Steam Heating Element	1500W	Cooling Fan	12W

Circuit Diagram

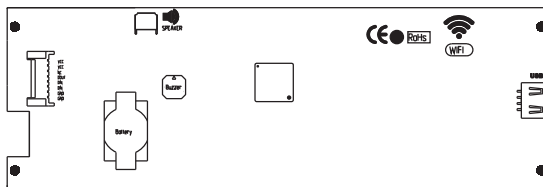
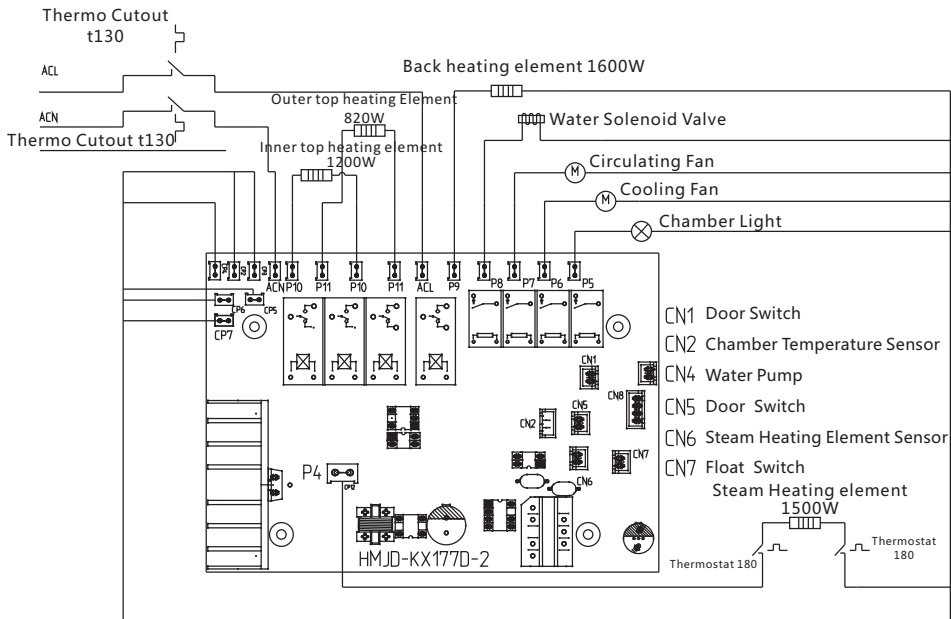

Disposal

This product must not be disposed together with domestic waste. This product has to be disposed at an authorised place for recycling of electrical and electronic appliances. By collecting and recycling waste, you help save natural resources, and make sure the product is disposed in an environment friendly and healthy way.



目录

前言	P29
注意事项	P29
接电注意事项	P30
纽扣电池	P31
安装说明	P31
技术参数	P33
蒸烤箱概况	P33
蒸烤箱配件清单	P34
蒸烤箱操作说明	P34
水箱清洁	P34
蒸烤箱设置说明	P36
烹饪档位描述	P43
清蒸建议时间表	P44
烘烤烹饪建议时间表	P45
清洁和维护	P46
一般故障分析	P49
电路图	P50
报废处理提示	P51

前言

尊敬的客户：

非常感谢您选择我们的产品。在开箱、安装、使用前，请正确、仔细阅读此说明书。

- 该产品必须由成人家中使用，在产品工作时，避免小孩触碰。
- 在产品工作时，若附近有小孩，必须由成人看护，以免靠近产品发生烫伤意外。
- 本产品安装接电必须遵循当地最新的电气法规。接电安装必须由具有资格的专业人员进行操作。
- 产品进行保养或者清洁前，必须断开电源，等待本产品完全降温后进行。
- 任何维修保养请直接联系具有资格的专业售后人员进行原装零配件更换。若使用非资格人员导致的产品损坏或相关的损失，不在保修范围。
- 如超过一个月没有使用本产品，建议在恢复使用前进行水箱清洁。

注意事项

- 更换蒸烤箱筒体内灯泡前请确保电源断开，避免发生触电意外。
- 本产品及其可能接触到的部分在使用过程中会发热。使用过程中避免触碰到发热管或者可能发热的零件。8岁以下的儿童请远离本产品，除非旁边有成人监督照顾，确保其安全。
- 不要使用粗糙擦洗剂或锋利金属清洁产品进行门玻璃清洁，因为它们会擦伤玻璃表面，从而导致玻璃破碎危险。
- 不能使用高压清洁器或蒸汽类清洁器清洁蒸烤箱，否则会发生短路、起火危险。
- 保护固定的电线。
- 安装蒸烤箱时，烤箱门需要最少离地85 mm以上。
- 安装的橱柜表面在蒸烤箱工作的时候有可能会产生发热情况。
- 如果电源线有损坏，请务必联系具有资质的售后维修人员更换原装电源线，或者联系厂家进行更换。
- 为了避免由于温控器的意外复位引起的危险，本产品不能通过外部开关装置进行连接，例如使用定时器；也不能连接到定期开关的公共用电设备上。
- 本产品必须年满8岁或以上健全有能力的儿童在成人的监管和指引下安全使用，并且了解其中可能的危险因数。禁止儿童玩耍本产品。保养和清洁等操作必须在成人监管陪同下进行。

- 警示: 如果是烹调含有脂肪或油脂的食品时, 请使用合适的蒸盘、烤盘或容器, 以免溢出的油脂高温引起着火的风险, 使用者必须在现场留意使用情况。如果发生着火禁止使用水来进行扑灭, 首先关掉电器产品, 然后用锅盖或者灭火毯盖灭火源。

警示: 不要在附近放置易燃物品。

- 警示 - 如果玻璃表面有裂痕, 请关闭蒸烤箱, 避免可能出现的电击危险。
- 警示 - 在使用烘烤功能时表面可触碰到的表面可能会变热, 儿童应该远离。
- 在进行清洁维护前, 应先清理多余的溢出物。
- 拿出层架烤盘等配件前应先关闭蒸烤箱。
- 清洁完成后, 需要依照说明正确放回层架或烤盘等配件。
- 如果有儿童出现可能, 并且可能触碰到烤箱门, 建议使用童锁功能。
- 不能放置金属物件在蒸烤箱内, 如刀叉、勺子、碗盖等可能会传热的物件。
- 根据条款11的测试要求, 储物抽屉的底部中间位置可能会变热, 需要在产品表面有警示高温的提示。
- 进行蒸烤箱清洁保养前需要关闭蒸烤箱并且拿出里面的配件, 清洁完成后把配件按说明要求安装回去。
- 安装完成后, 需要有可触碰到外部开关插座可断开本产品, 或者墙上插座有开关。
- 在完成本产品安装后, 需要在墙上电源插座上带有开关, 装好本产品后使用者依然能通关此开关关闭蒸烤箱。或者根据接线法规, 可以在固定电线上使用一个组合开关来实现。
- 8岁以下的儿童需要远离本产品, 或者必须全程有成人监督陪同。

接电注意事项

重要提示!

本产品安装接电必须遵循当地最新的电气条款、法规。必须由具有资格的专业售后人员进行安装。

重要提示!

本产品必须进行接地。

- 需要在固定电路上安装一个带开关的插座可以直接进行断电。
- 开关插座需要在完成产品安装后可以轻易接触到。
- 请查看参数规格说明确保电表、漏电开关、电源线和插座都符合产品最大功率要求。
- 为了确保正常工作, 需要常规检查接地安装。
- 接上电源后, 请确保电源线不会发生过热情况。
- 禁止使用排插、分流器或转接器, 这些设备可能会导致过热发生火灾危险。

- 电源线不要靠近或者放置在附近温度可能超过 50°C 的位置，以免引起电源线过热危险。

⚠️ 重要提示！ 由于错误安装导致的直接或间接损失，生产厂家概不负责。
安装人员必须确保产品的安装和电源的链接遵循当地的法规。

纽扣电池

在显示板的背部有一纽扣电池，纽扣电池型号：CR2032。

更换纽扣电池，

机器拔下电源，打开机器顶盖，电池在显示板后面。

轻压电池座边上卡销，电池弹起后轻取出电池。

安装新电池，电池+号一面为正极朝上，轻压如电池座即可。

- 不可充电的电池不能再进行充电；
- 不能混淆使用不同类的电池，新旧电池；
- 装入电池的时候注意正负极方向；
- 耗尽的电池要从电器中拆出，并且正确废弃投放；
- 如果电器长时间不使用，建议把电池拿出；
- 电源接线端不能短路。

安装说明

嵌入和安装要求：

- 橱柜开孔尺寸如图1所示。
- 蒸烤箱底部必须有层板支撑。
- 要确保橱柜内部预留足够的散热空间。
- 橱柜板材胶水等材料需要可以耐温达 120°C。



图 1

- 为了更有效的空气循环流动, 橱柜应当预留到后背板最少70mm的空间来确保蒸烤箱附近的足够的空气流动进行降温。
- 不能直接把橱柜背板贴在蒸烤箱的背部, 预留空位确保散热。参照图2。



图 2

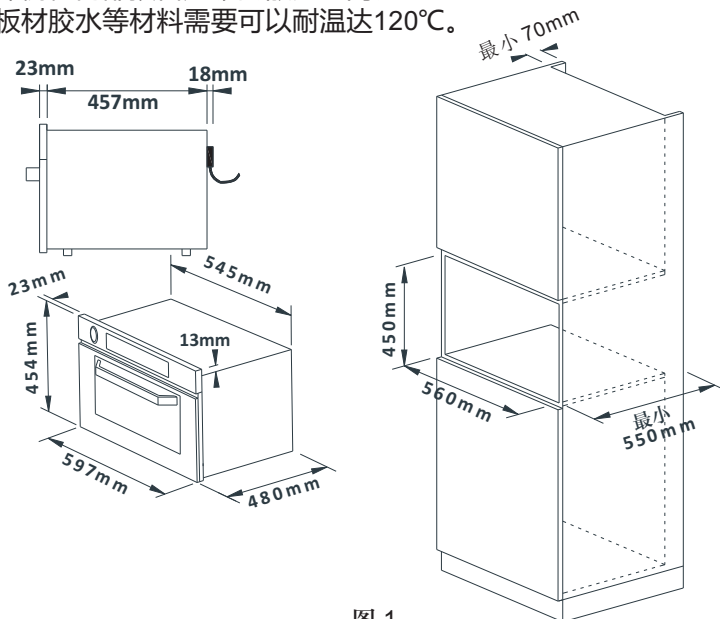

图 3

- 打开蒸烤箱门并且通过侧部支柱螺丝孔, 用四个本产品提供的螺丝钉来进行固定, 如图4所示。

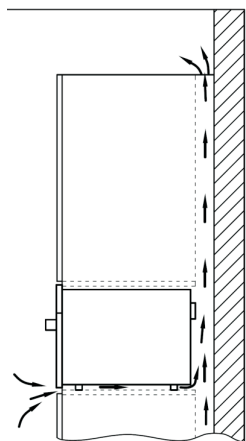

图 4

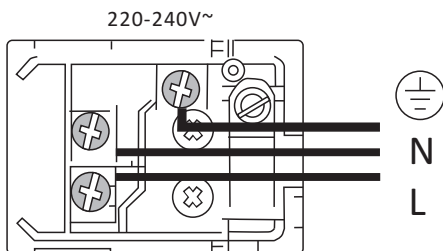
- 为了确保产品长期安全使用, 必须用绝对坚固的方法固定产品, 并且隔离电子元件, 以防止和金属配件接触的可能。所有带电设备和隔离电子元件需要固定, 并且必须使用工具才能拆除。
- 当进行电路安装连接时, 请在安装完毕后进行通电。

⚠ 重要提示!

本产品必须进行连接接地及漏电开关保护。如果发生电源线损坏的情况, 请及时联系专业售后服务人员进行更换。

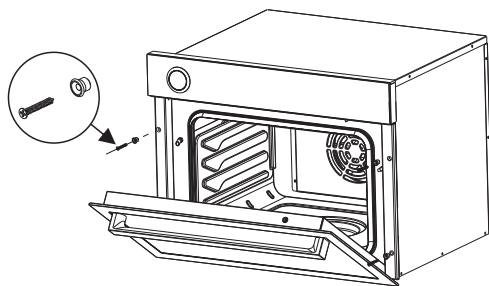
技术参数

产品名称	嵌入式蒸烤箱
产品型号	FV-ML71
额定电压	220 - 240V~
频率	50 - 60Hz
额定功率	2200W
蒸烤箱容量	45 L

蒸烤箱概况

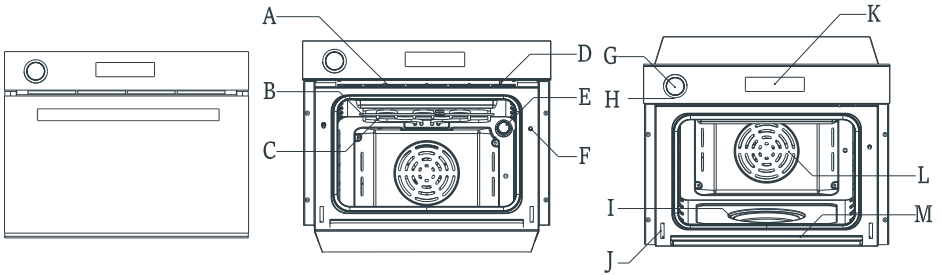

- A - 蒸烤箱排风口
- B - 上部外发热管
- C - 上部内发热管
- D - 童锁
- E - 蒸烤箱照明灯
- F - 门控开关

- G - 弹压式注水机构
- H - 水箱排水口
(按下弹压式注水机构，
弹出注水机构，排水口在
注水机构正下方。)
- I - 不锈钢发热盘
- J - 门铰链座
- K - 触摸显示屏
- L - 背部发热管
- M - 接水槽

蒸烤箱配件清单

不锈钢蒸盘		吸水海绵	
不锈钢托盘		量杯	
内层架		安装胶粒	
烘焙工具 套装		安装螺丝	

蒸烤箱操作说明

首次使用建议

在首次使用蒸烤箱前，建议：

- 拿出所有机子内的配件,并且清洁干净。
- 如果蒸烤箱玻璃门上覆盖有保护膜或纸,先把其去除。
- 先进行空机把各发热管调至最高温度进行45分钟加热工作,以去除发热管表面的涂层或者可能有的异味。
- 加热后关机等待蒸烤箱冷却后,使用肥皂水进行桶体清洁,并且用布擦干。
- 反复加水放水3次进行内置水箱清洁. 参看"水箱清洁"部分的说明。
- 最后设置纯蒸模式工作10分钟以清洁蒸模式系统。

水箱清洁

在使用蒸烤箱前，务必对内置水箱进行反复冲洗3次，以去除异味。

1. 打开电源，按下显示屏幕启动蒸烤箱。
2. 按下弹压注水机构以打开注水口，使用适当的量杯（1L）或水壶等容器进行加水。参看图5。
3. 打开蒸烤箱门，在弹压注水机构下方放置一个量杯或适合的容器。参看图6。



图 5



图 6

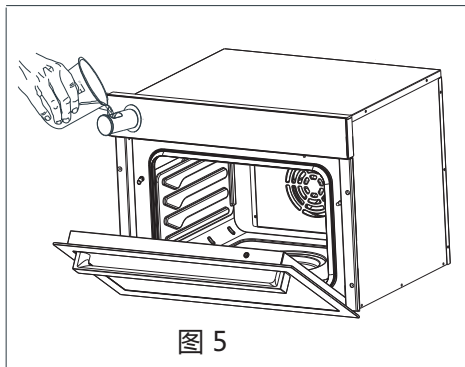

警示

注意：请使用合适的容器来装着排水口排出的内置水箱内的水。（排水口在弹压注水机构弹开后的正下方）

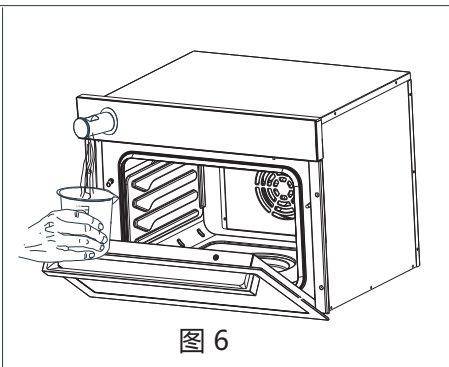
建议每次使用完蒸烤箱后排清内置水箱内剩下的水，以免滋生细菌。

4. 按下显示屏左上角的排水图标  进行排水。期间蒸烤箱门必须保持打开状态。



5. 用适当的容器接着排出的水，直到内置水箱的余水排干净，并且重复过程2次。



重要提示！如果超过一周时间未使用蒸烤箱，务必先进行水箱清洁，再使用蒸烤箱进行烹调。



重要提示！尽可能使用过滤水或纯净水加入蒸烤箱进行纯蒸或蒸烤功能，以防水质不好引起水垢堵塞。



警示！在蒸烤箱工作时，避免儿童在附近玩耍发生意外。

蒸烤箱设置说明

1. 插上电源后，触点显示屏开启蒸烤箱。



烤：烤功能可以用来烤肉类、面包、西点等。

蒸：蒸功能可以用来蒸肉类、鱼类、蔬菜、包点、米饭等，利用低温可以发酵面团、制作酸奶等。

蒸烤：先蒸后烤功能可以使食物达到外脆、里嫩、汁多。

菜谱：智能菜谱可以帮助新手用户一键烹饪。

设置：蒸烤箱的基础设置功能，如日期时间，选择中文/英文操作系统，系统云更新，连接Wi-Fi等。

网络配置：进入设置，连接Wi-Fi；或点击右上角Wi-Fi图标。Wi-Fi连接成功后，开启你的体验之旅。

2. 烘烤

进入烘烤菜单选择需要烘烤的类别。



● 选择了烘焙食物种类后,显示屏会显示默认烘焙时间,温度,可以滑动屏幕上的时间和温度调整所需工作的时间和温度,然后按下▶ 启动键,蒸烤箱开始工作。

一共有8种烘烤模式可选择。



进入工作中状态后,界面保持常亮,用户能实时并直观地观察到蒸烤箱运行的时间和当前工作温度。



蒸烤箱工作结束后,显示屏会出现提示工作结束语,点击“OK”,烤箱门童锁打开。



3. 纯蒸设置

- 菜单中选择需要蒸煮的食物种类, 然后在子菜单中选择所需食物。



子菜单种类：



- 选择了需要蒸煮食物种类后,显示屏会显示默认工作时间,温度,可以滑动屏幕上的时间和温度调整所需工作的时间和温度,然后按下启动键,蒸烤箱开始工作。





- 设定完成后进入工作中状态后，界面保持常亮，用户能实时并直观地观察到蒸箱运行的时间及当前温度。工作中用户随时能暂停及停止工作。



蒸烤箱工作结束后，显示屏会出现提示工作结束语，点击“OK”，烤箱门童锁打开。



- 纯蒸工作注意事项及警示

蒸烤箱启动工作后，童锁自动启动。如果在蒸烤箱工作过程中需要查看食物情况，需要按下  暂停键，童锁解开。恢复蒸烤箱工作，关上烤箱门后，重新按下  启动键。

如果蒸烤箱刚结束工作，立马打开门，会有大量蒸汽泄出，如需立马开门，务必尽量远离门打开的位置，直到蒸汽排完，再拿出里面煮好的食物。

为了减少工作结束后发热盘剩下的水分，工作时间的最后3分钟蒸烤箱的水泵会停止放水到发热盘，发热盘里面剩余的水分会继续加热产生蒸汽直到水干，发热盘停止加热。最后3分钟可能会出现温度下降的情况，是因为发热盘里面剩余的水分已经烧干，发热盘停止工作，温度下降属正常情况。

蒸烤箱接近工作时间尾端会有少量蒸汽从前面的风道泄出，注意安全，防止发生蒸汽烫伤。由于发热盘里面剩下的水分烧干及风道发出蒸汽，工作时间的最后一分钟桶体内温度会下降。有可能工作结束后发热盘还剩下水，属于正常情况。

冷却风机会在蒸烤箱工作结束后继续工作15分钟。

警示！蒸烤箱玻璃门的温度在工作过程中有可能上升到 55℃。

警示！当蒸烤箱工作刚结束后，如需要立马开门，务必先打开一条门缝让蒸汽缓慢泄出，以免发生烫伤意外。

4. 蒸烤联动功能设置

- 在蒸烤菜单里面选择所需烹饪的食物种类，然后子菜单里面选择。



- 选择了需要烹饪食物种类后,显示屏会显示默认工作时间,温度,可以滑动屏幕上的时间和温度调整所需工作的时间和温度,然后按下启动键,蒸烤箱开始工作。先蒸后烤联动功能有2种模式选择。

滑动左侧或点击底部模式栏切换加热模式。



- 设定完成后进入工作中状态后，界面保持常亮，用户能实时并直观地观察到蒸烤箱运行的时间及当前温度。工作中用户随时能暂停及停止工作。



蒸烤箱工作结束后，显示屏会出现提示工作结束语，点击“OK”，烤箱门童锁打开。



5. 高温蒸功能

- 高温蒸功能可以用来炖汤，炖肉或缩短普通正常蒸煮的时间。

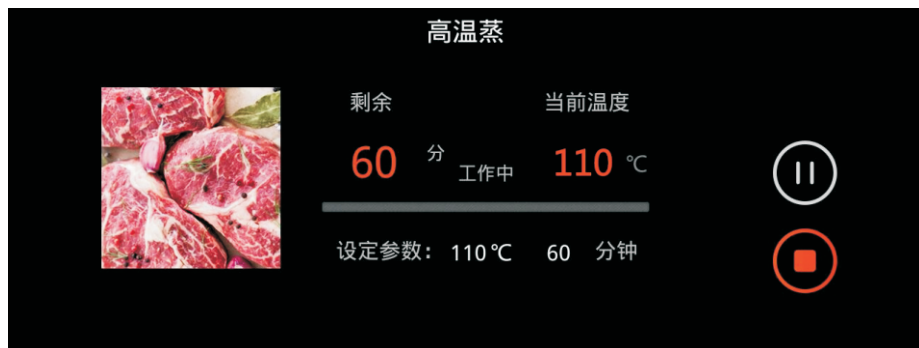

6. 菜谱

- 蒸烤箱具有菜谱选项, 里面有准备步骤和一键启动, 让烹调更轻松, 简单。











7. 设置

- 在设置菜单里, 可以进行Wi-Fi网络连接, 调节显示屏的亮度, 设置当地时间, 选择操作语言(中文或英文), 或者更新操作系统。





烹饪档位描述

● 烘烤档位

档位图标	档位名称	功能描述
	背部发热管 + 循环风机	背部发热管和循环风机工作，热量可以均匀分布在各层，适用于同时在不同层烘烤食物。此档适用于同时烤多种食物。
	上部内、外发热管 + 循环风机	上部内、外发热管和循环风机一起工作。风机有助于热量均衡，适合外焦里嫩的食物。
	上部内、外发热管	上部内、外发热管一起工作，更合适用在数量比较大的食物烘烤。
	上部内发热管	上部内发热管工作，热量直接从顶部直到食物表面，合适比较少量的食物。
	上部内发热管 + 循环风机	上部内发热管加上循环风机共同作用，使后面和前面的热量更加均匀到烤盘的各个位置。适合少量的食物烘烤使用。
	上部内发热管 + 背部发热管 + 循环风机	上部内发热管和背部发热管加上循环风机作用，筒体内热量均匀分布，使食物表面金黄。适合数量大的食物。
	解冻	单纯循环风机转动，可以用来解冻食物。解冻所需时间要根据食物的类型和数量及室内温度进行设定。
	上部外发热管	上部外发热管的热量直接从顶部到达食物，让食物外表金黄，也适合用来慢烤和再加热食物。

● 蒸烤联动档位

档位图标	档位名称	功能描述
	先蒸，后背部发热管 + 循环风机烤	先蒸，然后背部发热管和循环风机工作进行烘烤食物，过程更有效率，食物保持水分同时还有金黄外表。
	先蒸，后上部内、外发热管 + 循环风机	先蒸，然后上部内、外发热管和循环风机一起工作进行烘烤，使过程更快，热量更均匀，适合保持食物水分同时能有外焦里嫩的效果。

清蒸建议时间表

食物种类	设置温度(°C)	工作时间(分钟)
蔬菜类		
西兰花(小块切开)	100	6-8
椰菜花	100	6-8
椰菜花(小块切开)	100	6-8
青豆	100	8-10
豌豆	100	10
土豆(去皮切小块)	100	20-25
土豆(带皮)	100	30-35
红萝卜(切开小块)	100	6-8
芦笋	100	10-14
肉类 & 香肠		
整鸡	100	20-25
鸡(切块)	100	6-7
香肠	90	5
排骨	100	7-9
猪肉	100	10-15
鱼类		
三文鱼排	100	7-10
比目鱼排	100	7-10
豆类		
浸湿的扁豆	100	10-15
干豆	100	22-25
干的小扁豆	100	20-22
米饭 & 谷类		
小麦	100	10
粥	100	15-20
全麦类	100	16-35
煮蛋		
温泉蛋	100	5
半生熟水煮蛋	100	5-6
全熟水煮蛋	100	8-10
水果类		
切块的苹果/梨	100	5
樱桃	100	5
掌叶大黄	100	5
炖汤	100	40-80

⚠️ 重要提示！以上参数仅供参考。蒸煮时间需要根据实际食物需求调整。在蒸煮过程中可以通过烤箱门中间透明部分查看食物情况。使用过程中熟悉最合适的烹调温度和时间设置模式。

烘烤烹饪建议时间表

食物	建议放置位置	烤箱温度(°C)	烘烤时间(分钟)
常规食物	2	200~225	根据食物数量
慢烤	2	200~225	50~60
鸭	2	200~220	40~55
家禽	1	200~225	根据食物数量
鱼类	1	190~220	20~30
糕点	底层	160~200	15~20
披萨	2	160~180	25~30
小牛排	3	190~220	20~30
小羊排	3	190~220	20~30
肝脏	3	190~225	10~12
肉末	3	190~225	12~15
牛心肉	3	190~220	12~15
网烤肉	3	190~220	20~30
半鸡	3	200~220	40~55
鱼排	3	190~220	12~15
焗番茄	3	190~220	10~15
烤土豆	3	180~220	40~60

 **重要提示！**以上参数仅供参考。蒸煮时间需要根据实际食物需求调整。在蒸煮过程中可以通过烤箱门中间透明部分查看食物情况。使用过程中熟悉最合适的烹调温度和时间设置模式。

 **重要提示!**在烘烤前请先进行烤箱预热。

 **实用建议!**如果烘烤带骨头的肉类请增加10-15分钟工作时间。

 **实用建议!**尽量减少工作过程中打开烤箱门,减少热量散发,节约能。

也可以在工作时间结束前几分钟关掉烤箱,利用预热完成烘烤。

清洁和维护

内置水箱

重要提示！为了避免产生水垢，滋生细菌，请每次使用完蒸烤箱后，把内置水箱内的余水排清。

烤箱清洁

请仔细阅读说明。

警示！在进行清洁和维护前，请先断开电源。

警示！禁止使用蒸汽清洁器清洁蒸烤箱。否则会损坏线路板和控制面板。

重要提示！只能使用中性清洁剂。不能使用粗糙擦洗剂或锋利金属清洁产品, 会刮花筒体表面。

层架和烤盘

使用后及时清洁层架和烤盘。

接水槽

使用完纯蒸功能后，如果接水槽有积水，请及时吸干、清洁。

门密封胶条

在使用蒸烤箱后，请用海绵用肥皂水进行门密封条清洁。

重要提示！如果发现门密封胶条损坏，请及时联系专业售后维修人员进行更换。

筒体清洁

在使用完蒸烤箱后，用浸湿中性清洁剂的湿海绵进行清洁，然后用干净毛巾擦干。一般的污渍都能擦除。如果所使用的的水质比较硬或者含杂质比较多，有可能会在筒体或发热盘上产生水垢或水渍。请使用湿毛巾浸湿白醋擦拭，或者发热盘内加入白醋、柠檬汁加热去除水垢。

不锈钢发热盘

在使用一段时间后，不锈钢发热盘表面可能会形成水垢，加入5%的柠檬酸清洁剂使用温水，或者直接滴入白醋可以清洁去除。

蒸烤箱门

请使用玻璃清洁剂进行蒸烤箱门清洁。

拆除蒸烤箱门

为了更容易清洁筒体内部,可以把蒸烤箱门拆除。

1. 把蒸烤箱门完全打开,如下图所示。
2. 把左右铰链的卡位片图B翻起。
3. 双手提起烤箱门两边,然后向关合方向提起抽出。
4. 把蒸烤箱门按照图所示步骤拆离机体。

安装回蒸烤箱门,请确保卡槽D正确卡到铰链座位置上,把门完全打开后,将铰链卡片向内压下卡住铰链。关上门然后检查位置是否正确。

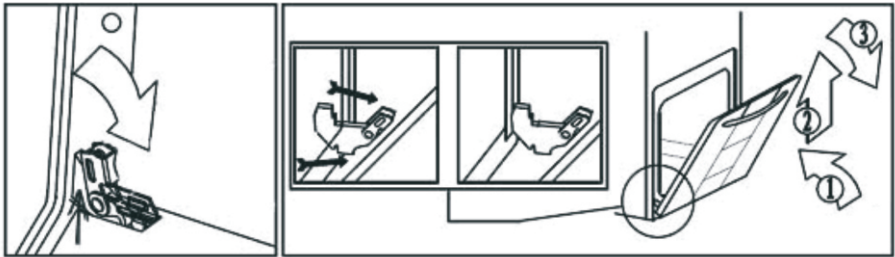
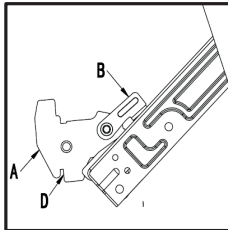

不锈钢面板

如果有不锈钢面板,请使用柔软抹布,用肥皂水擦拭进行清洁。然后用干布擦干。

使用不含研磨剂的专用清洁剂按照不锈钢纹路方向擦拭不锈钢。

警示！不能使用研磨化学清洁剂,或粗糙的抹布清洁不锈钢表面,若使用此类物品导致丝印缺失,不涵盖在保修范围内。

警示！不能使用蒸汽清洁器,若使用了蒸汽清洁器导致蒸烤箱损坏或故障,保修不涵盖。

警示！不能使用含有苏打,酸性或含氯清洁剂。

警示！不能使用清洁喷雾器,粗糙的研磨清洁剂或锋利金属球去清洁烤箱,这些物品会导致不锈钢表面划痕刮花。

注意！如果污渍长期沾附在不锈钢表面不进行清洁，有可能会導致不锈钢表面的永久性污渍痕迹。

每次使用完蒸烤箱，建议及时清洁脏污油脂，避免脏污堆积和产生难闻异味。蒸烤箱筒体内的层架、烤盘等配件均可拿出进行清洁，和普通厨房器具一样清洁方法。

在清洁完所有的配件和蒸烤箱表面后，等完全干透，再插电进行下一次使用。

更换蒸烤箱筒体照明灯

为了避免触电意外发生，必须在进行更换灯泡前完全切掉电源。然后更换一个新的可以耐高温300°C的新灯泡。

灯泡规格为：

电压: 220-240V~ 功率: 15W E14

更换好灯泡后，重新按上灯罩后，最后打开蒸烤箱电源。

一般故障分析

保养及维修工作必须由符合资质的售后人员进行。

注意！由不符合资质的人员维修会有维修，因擅自修理或由不符合资质的人员维修导致的直接或间接损失，厂家概不负责。

故障	可能导致的原因及解决建议
蒸烤箱不通电。	检查电源开关是否打开。 检查插座是否有电到。 如果发现插座没有电，请联系正规电工维修。 如果插座有电，请联系具有资格的售后服务部。
如果纯蒸功能的时候没有加热产生蒸汽。	检查蒸烤箱门是否关好。 检查内置水箱里是否已经加水。 如果以上都没问题，检查发热盘的保险丝是否完好，或联系具有资格的售后服务部。
如果纯蒸功能加热时间过长。	检查不锈钢发热盘上是否有比较厚的一层水垢，及时清理发热盘上的水垢。 如果问题依然不能解决，请联系具有资格的维修服务部上门检查维修。 检查是否门密封胶条有损坏，如发生损坏，请及时联系售后服务部进行更换。

产品技术参数表

产品型号	FV-ML71	额定功率	2200W
		背部发热管功率	1600W
额定电压	220-240V~	上部外发热管功率	820W
额定频率	50-60Hz	上部内发热管功率	1200W
照明灯功率	15W	循环风机功率	30W
发热盘功率	1500W	冷却风机功率	12W

电路图

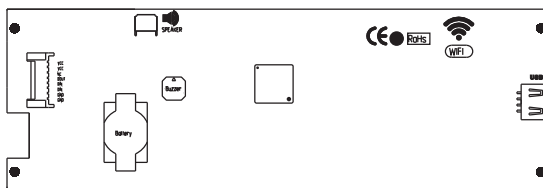
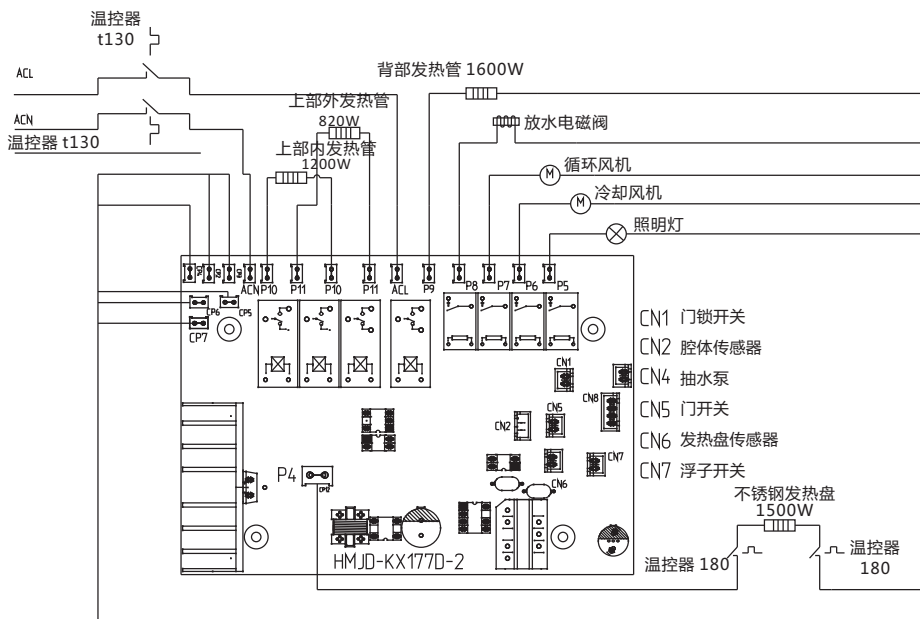

报废处理提示

本产品不能和普通家用垃圾一起丢弃。需要丢弃在专门电子或电气产品废品回收的指定地方。为了保护环境及安全, 循环利用, 请确保产品丢弃在指定的安全回收地方。



Global Website
<https://global.fujioh.com>

FUJIOH INTERNATIONAL TRADING PTE.LTD.

Southeast Asia Regional Headquarters
3014A Ubi Road 1 #06-04, Singapore 408703
Tel: (65)6286 3286 Fax:(65)6285 3285
E-mail: fit@fujioh.com.sg

FUJIOH MARKETING MALAYSIA SDN. BHD.

23, Jalan Serendah 26/39, Section 26, 40400
Shah Alam, Selangor, Malaysia
Tel: (60)35103-6826
E-mail: enquiry@fujioh.my